

NOTE:
 -INSTALLER IS RESPONSIBLE FOR PROPER
 INSTALLATION AND FOUNDATION BASED
 ON SITE WIND LOADING AND LOCAL BUILDING CODES.
 -SUBJECT TO LOCAL STRUCTURAL ENGINEERING APPROVAL

NOTE:
 -TO BE WIRED BY QUALIFIED TECHNICIAN
 IN ACCORDANCE WITH LOCAL ELECTRICAL CODES.

REVISIONS				
REV.	DESCRIPTION	DATE	BY	APPROVED
-	INITIAL RELEASE	05/24/2017	AT	

NOTES:

- ① -
- ② -
- ③ -

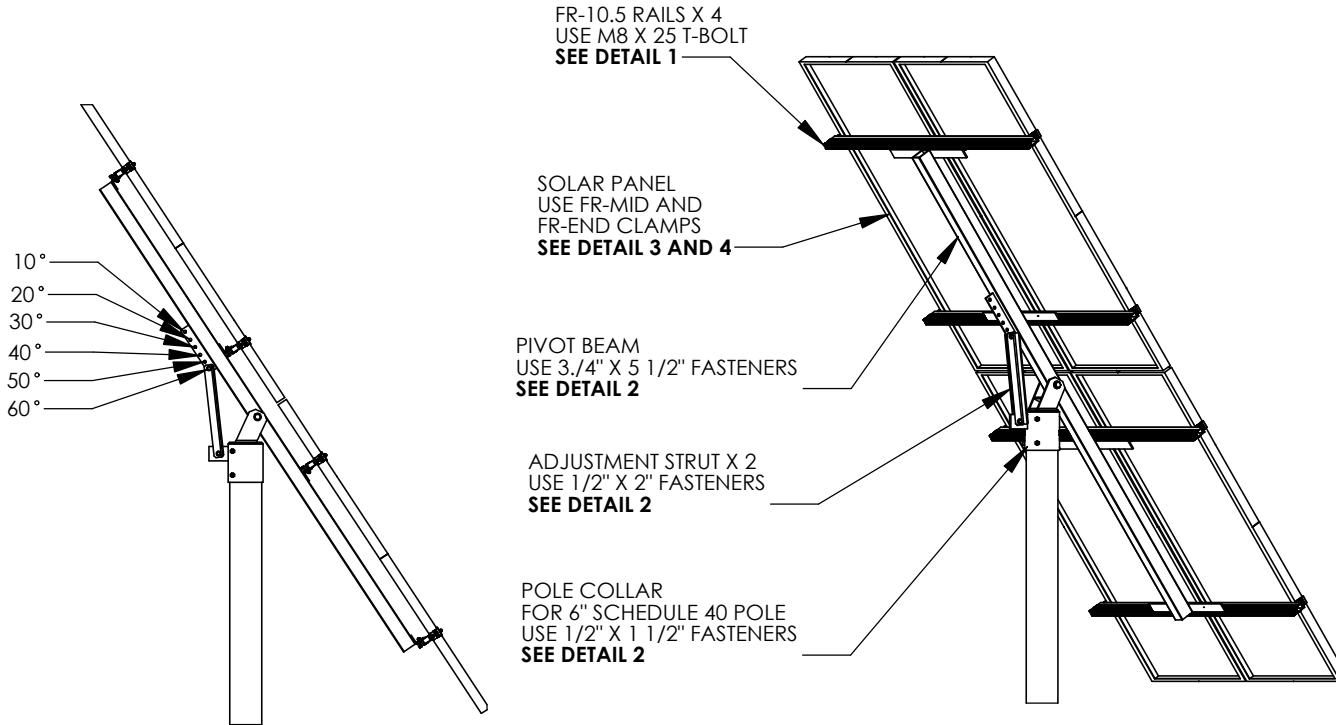

H.E.S. PV

84 MORROW RD.
 BARRIE, ON L4N 3V8
 1-866-258-0110
 WWW.HESPV.COM

PROJECT:

-

USED ON ASSY:

-

CLONE FROM:

100888

UNLESS OTHERWISE SPECIFIED:

DIMENSIONS ARE IN INCHES
 TOLERANCES:
 FRACTIONAL $\pm 1/16$
 ANGULAR: MACH \pm BEND \pm
 TWO PLACE DECIMAL ± 0.06
 THREE PLACE DECIMAL ± 0.03

INTERPRET GEOMETRIC
 TOLERANCING PER:

MATERIAL:

FINISH:

NAME

DATE

DRAWN

AT

5/24/17

CHECKED

-

-

ENG APPR.

MFG APPR.

Q.A.

TITLE: FR-TPM4-UNI ASSEMBLY

DWG. NO.

105331

REV

-

SCALE: NTS

SHEET SIZE: A

SHEET 1 OF 4

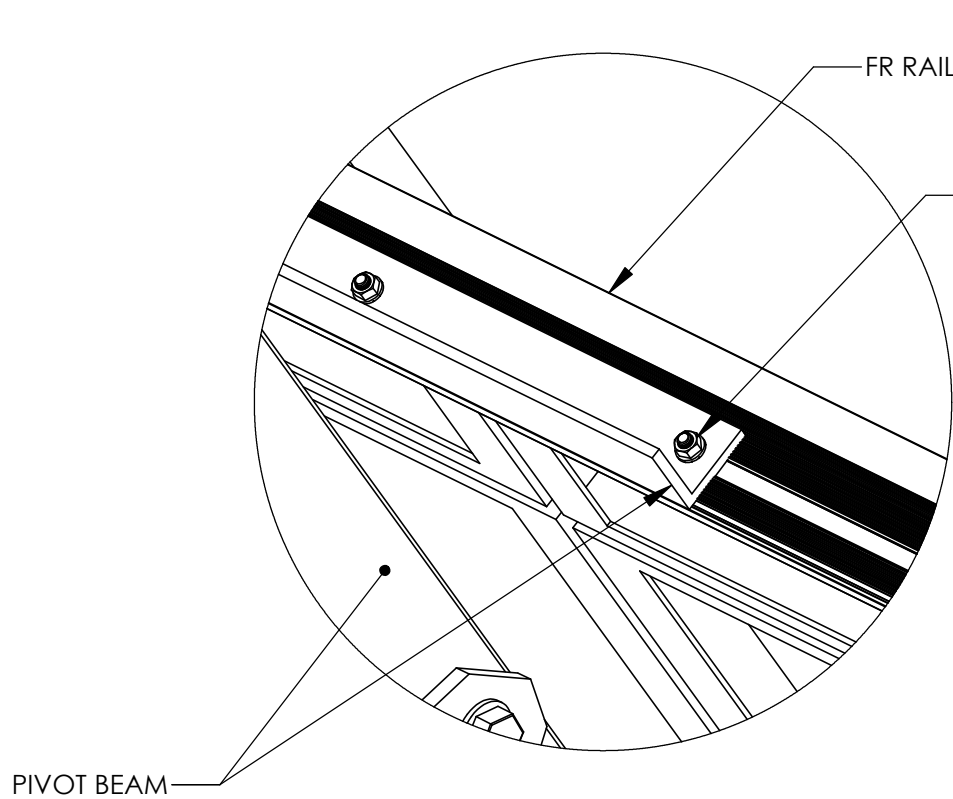

DETAIL 1
M8 X 25 T-BOLT
FR-10.5 RAIL TO PIVOT BEAM

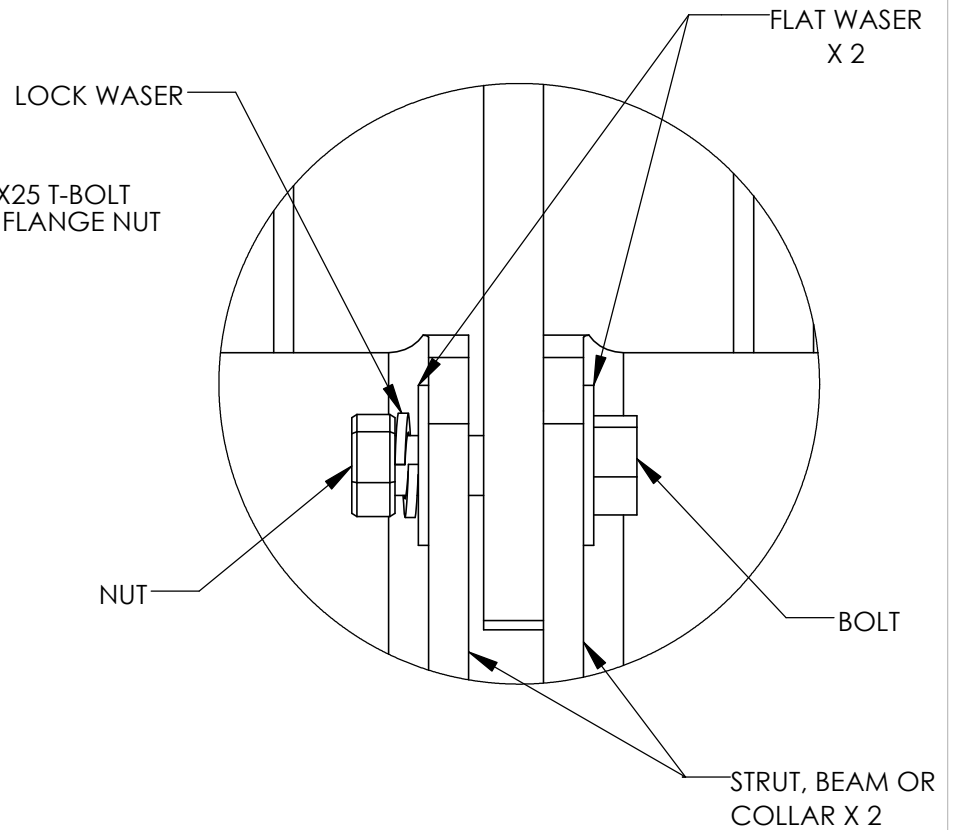

DETAIL 2
Ø3/4, Ø1/2" & Ø3/4" FASTENERS

H.E.S. PV

84 MORROW RD.
BARRIE, ON L4N 3V8
1-866-258-0110
WWW.HESPV.COM

PROJECT:

-

USED ON ASSY:

-

CLONE FROM:

100888

UNLESS OTHERWISE SPECIFIED:

DIMENSIONS ARE IN INCHES
TOLERANCES:
FRACTIONAL ± 1/16
ANGULAR: MACH ± BEND ±
TWO PLACE DECIMAL ± 0.06
THREE PLACE DECIMAL ± 0.03

INTERPRET GEOMETRIC
TOLERANCING PER:

MATERIAL:

FINISH:

DRAWN

NAME

AT

DATE

5/24/17

CHECKED

-

ENG APPR.

MFG APPR.

Q.A.

TITLE: FR-TPM4-UNI ASSEMBLY

DWG. NO.

105331

REV

-

SCALE: NTS

SHEET SIZE: **A**

SHEET 2 OF 4

1/2" x 2" STAINLESS STEEL BOLT x 2
 1/2" STAINLESS STEEL FLAT WASHER x 4
 1/2" STAINLESS STEEL LOCK WASHER x 2
 1/2" STAINLESS STEEL NUT x 2

3/4" X S 1/2" STEEL BOLT X 1
 3/4" STEEL FALT WASHER X 2
 3/" STEEL LOCK WASHER X 1
 3/4" STEEL NUT X 1

1/2" X 1 1/2" STEEL BOLT X 4

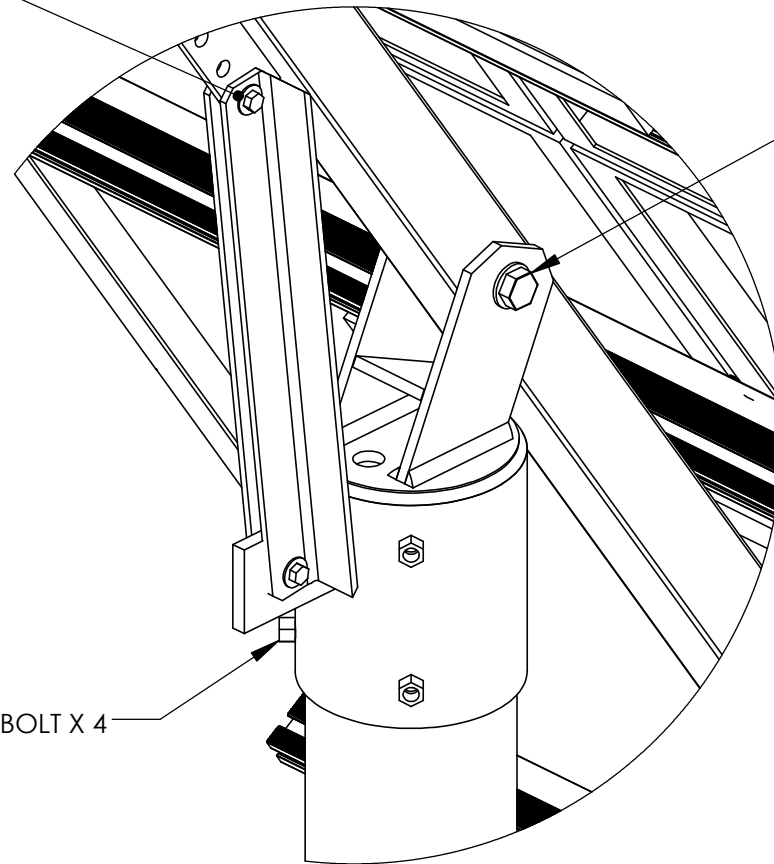

H.E.S. PV

84 MORROW RD.
 BARRIE, ON L4N 3V8
 1-866-258-0110
 WWW.HESPV.COM

PROJECT:

-

USED ON ASSY:

-

CLONE FROM:

100888

UNLESS OTHERWISE SPECIFIED:

DIMENSIONS ARE IN INCHES
 TOLERANCES:
 FRACTIONAL ± 1/16
 ANGULAR: MACH ± BEND ±
 TWO PLACE DECIMAL ± 0.06
 THREE PLACE DECIMAL ± 0.03

INTERPRET GEOMETRIC
 TOLERANCING PER:

MATERIAL:

FINISH:

DETAIL G
 SCALE 1 : 6

MFG APPR.
 G.A.

NAME

AT

-

ENG APPR.

MFG APPR.

G.A.

DATE

5/24/17

-

-

-

-

TITLE: FR-TPM4-UNI ASSEMBLY

DWG. NO.

105331

REV

-

SCALE: NTS

SHEET SIZE: A

SHEET 3 OF 4

NOTES:

-BONDING WASHER TO BE USED ON EVERY MID CLAMP

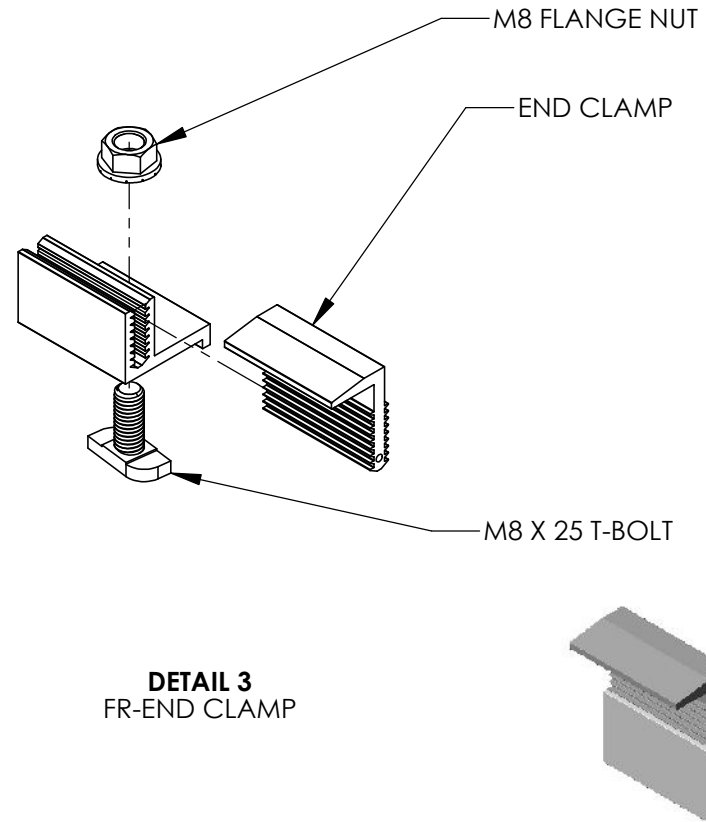
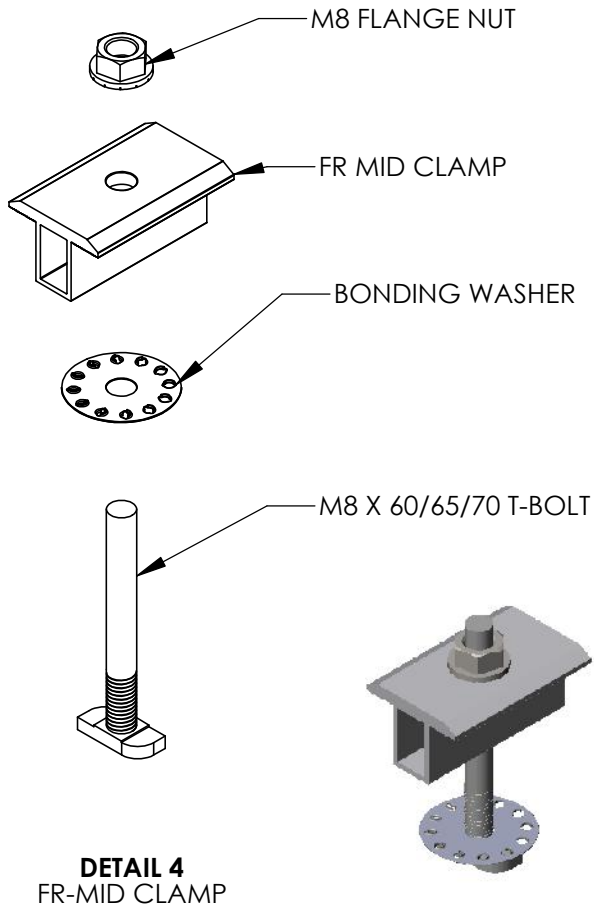

H.E.S. PV

84 MORROW RD.
BARRIE, ON L4N 3V8
1-866-258-0110
WWW.HESPV.COM

PROJECT:

-

USED ON ASSY:

-

CLONE FROM:

100888

UNLESS OTHERWISE SPECIFIED:

DIMENSIONS ARE IN INCHES
TOLERANCES:
FRACTIONAL $\pm 1/16$
ANGULAR: MACH \pm BEND \pm
TWO PLACE DECIMAL ± 0.06
THREE PLACE DECIMAL ± 0.03

INTERPRET GEOMETRIC
TOLERANCING PER:

MATERIAL:

FINISH:

NAME

DATE

DRAWN

AT

5/24/17

CHECKED

-

-

ENG APPR.

MFG APPR.

Q.A.

TITLE: FR-TPM4-UNI ASSEMBLY

DWG. NO.

105331

REV

-

SCALE: NTS

SHEET SIZE: A

SHEET 4 OF 4

5

4

3

2

1

PROPRIETARY AND CONFIDENTIAL
THE INFORMATION CONTAINED IN THIS DRAWING IS THE SOLE PROPERTY OF
HOME ENERGY SOLUTIONS. ANY REPRODUCTION IN PART OR AS A WHOLE
WITHOUT THE WRITTEN PERMISSION OF H.E.S. PV IS PROHIBITED.