

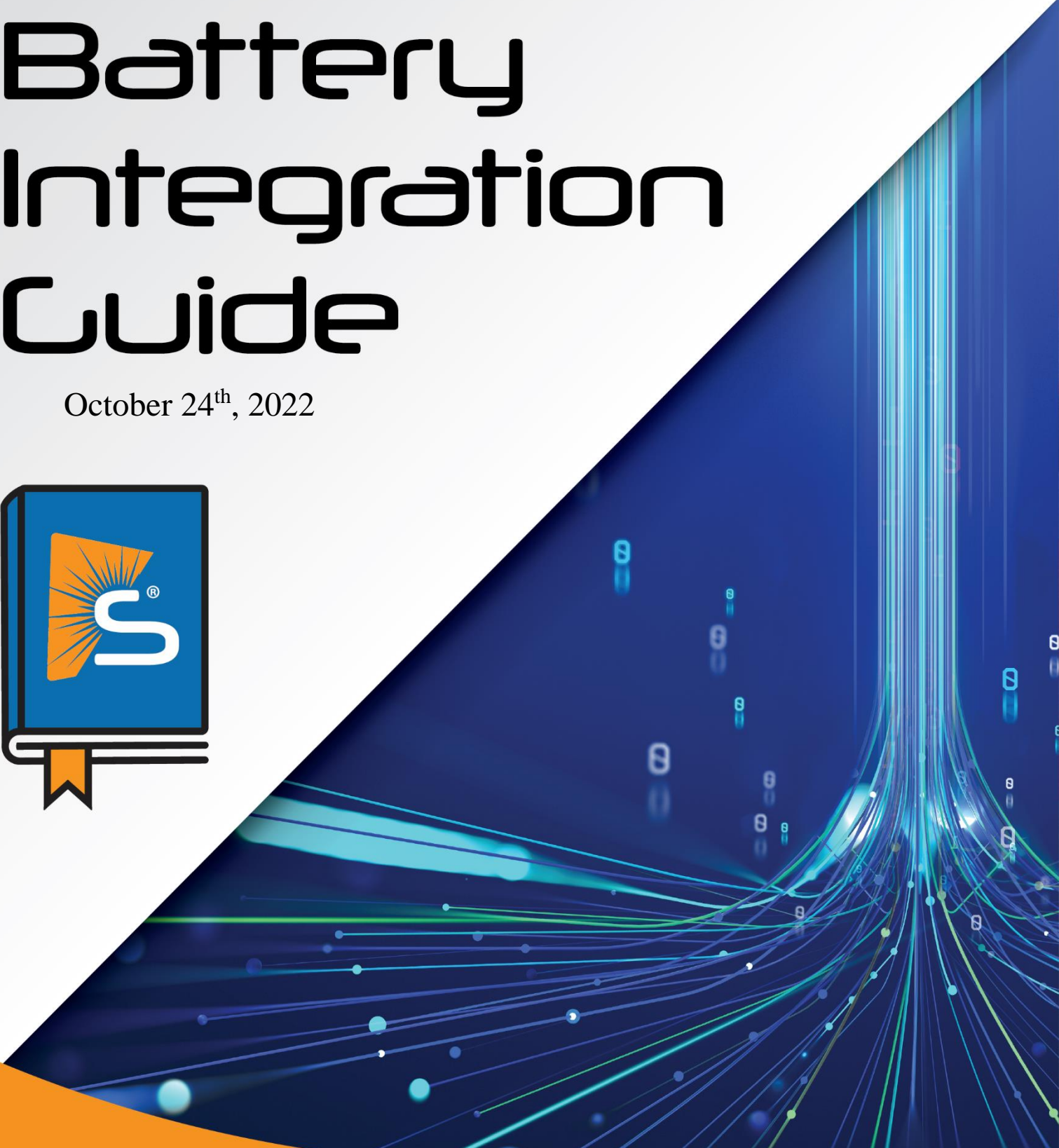

Battery Integration Guide

October 24th, 2022



| | |
|-------------------------------------------|-----------|
| TABLE OF CONTENTS..... | 2 |
| GENERAL HARDWARE CONFIG | 3 |
| SOL-ARK 8K (INDOOR) | 3 |
| SOL-ARK 12K (INDOOR) | 3 |
| SOL-ARK 5K / 8K / 12K- 2P (OUTDOOR) | 4 |
| SOL-ARK 15K..... | 4 |
| INVERTER BMS DATA DISPLAY | 5 |
| CAN BUS BATTERY SCREEN | 5 |
| MODBUS/RS-485 BATTERY SCREEN..... | 6 |
| COMPATIBLE BATTERY GUIDE..... | 7 |
| DISCOVER | 7 |
| DYNES | 8 |
| BLUE ION/EGAUGE | 9 |
| BLUE ION/NAMAKA | 10 |
| FORTRESS eFLEX 5.4 | 11 |
| FORTRESS eVAULT & eVAULT MAX 18.5 | 12 |
| STORZPOWER..... | 13 |
| SIMPLI PHI AMPLI PHI..... | 14 |
| NUENERGY LITHIUM | 15 |
| NUENERGY LITHIUM- POWER BASE M50 | 16 |
| POWERSYNC 51.2V LITHIUM..... | 17 |
| KILOVAULT HAB..... | 18 |
| SACRED SUN LFP | 19 |
| HOMEGRID STACK'D | 20 |
| DEKA-DURATION-DD5300..... | 21 |
| PYLONTECH US3000C | 22 |
| PYTES E-BOX-48100R..... | 23 |
| ENDURENERGY ESP-5100 | 24 |
| UZ ENERGY POWER LITE (L051100-B) | 25 |
| INCELL / POLARIUM..... | 26 |
| RENOGY AURA | 27 |
| CHANGELOG NOTES..... | 28 |

Sol-Ark 8K (Indoor)

The Sol-Ark 8K can communicate through the RJ-45 ports labeled “RJ45_485” and “RJ45_CAN” or the terminal connectors for RS-485 and CAN.

The ports are shown in detail below, alongside pin diagrams and detailed pin configurations for each port.

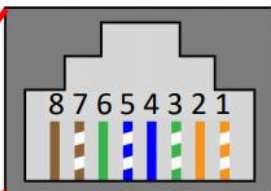
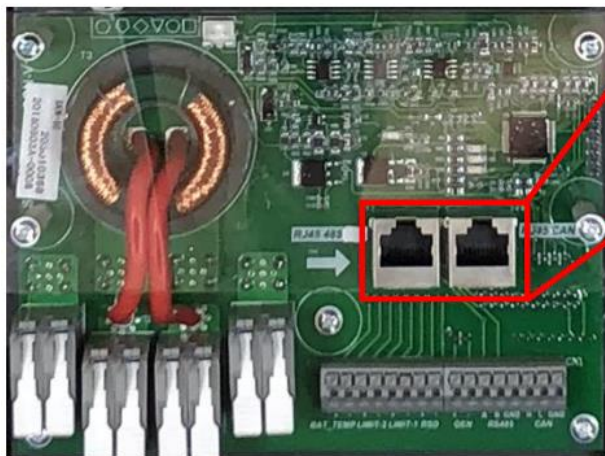

| Pin | Function |
|-----|-----------|
| 1 | RS-485 B- |
| 2 | RS-485 A+ |
| 3 | GND |
| 4 | |
| 5 | |
| 6 | GND |
| 7 | RS-485 A+ |
| 8 | RS-485 B- |

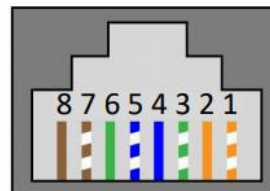

| Pin | Function |
|-----|----------|
| 1 | |
| 2 | GND |
| 3 | |
| 4 | CAN Hi |
| 5 | CAN Lo |
| 6 | |
| 7 | |
| 8 | |

Sol-Ark 12K (Indoor)

The Sol-Ark 12K can communicate through the RJ-45 ports labeled “RS-485” and “CAN.”

The ports are shown below in detail, alongside pin diagrams and detailed pin configurations for each port.

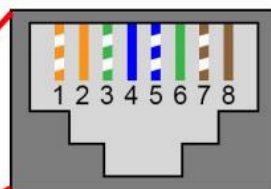
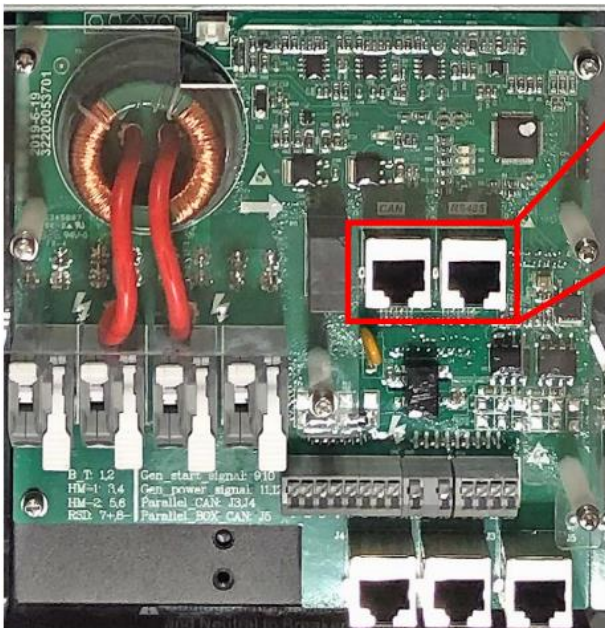

| Pin | Function |
|-----|----------|
| 1 | |
| 2 | GND |
| 3 | |
| 4 | CAN Hi |
| 5 | CAN Lo |
| 6 | |
| 7 | |
| 8 | |

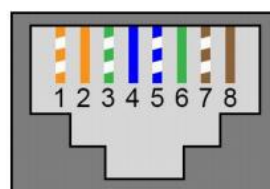

| Pin | Function |
|-----|-----------|
| 1 | RS-485 B- |
| 2 | RS-485 A+ |
| 3 | GND |
| 4 | |
| 5 | |
| 6 | GND |
| 7 | RS-485 A+ |
| 8 | RS-485 B- |

Sol-Ark 5K / 8K / 12K- 2P (Outdoor)

The Outdoor-Rated Sol-Arks achieve communications through a single RJ-45 port labeled “Battery CAN Bus.” This port combines the pin configurations of the RS-485 and CAN port on the indoor-rated 12K.

The port is shown below in detail, alongside a pin diagram and detailed pin configuration.

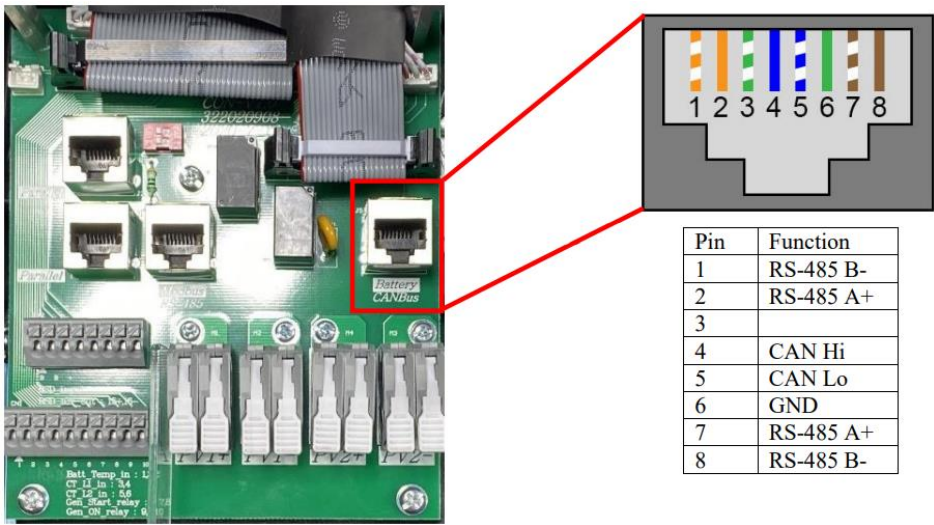

NOTE: The outdoor-rated systems and Sol-Ark 15K inverters have a “Modbus RS-485” port, which is not for battery communications and is currently not implemented.

Sol-Ark 15K

The Sol-Ark 15K inverter achieves communications through a single RJ-45 port labeled “Battery CAN Bus.” This port combines the pin configurations of the RS-485 and CAN port on the indoor-rated 12K.

The port is shown below in detail, alongside a pin diagram and detailed pin configuration.

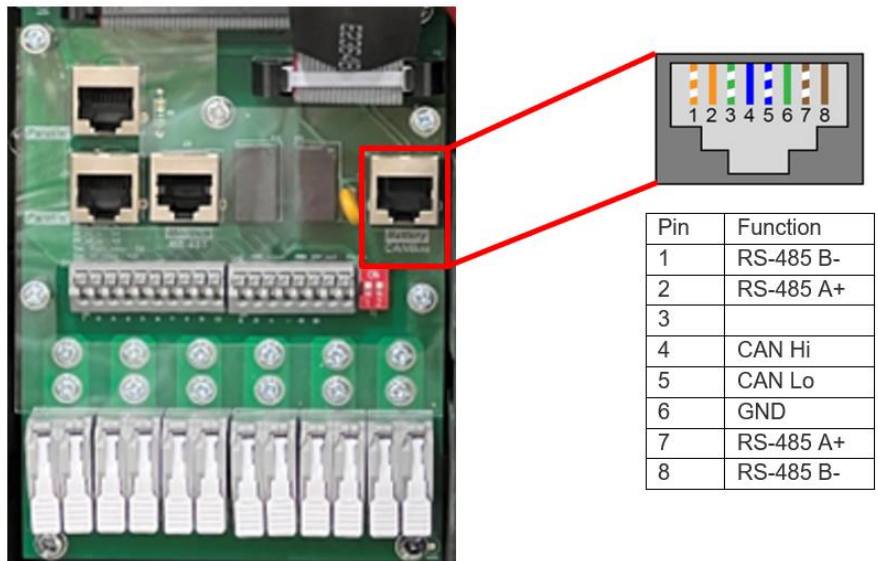

CAN Bus Battery Screen

The image below depicts the screen shown under “Settings > LI Batt Info” when communications are enabled for CAN Bus batteries (“BMS Lithium Batt 00”).

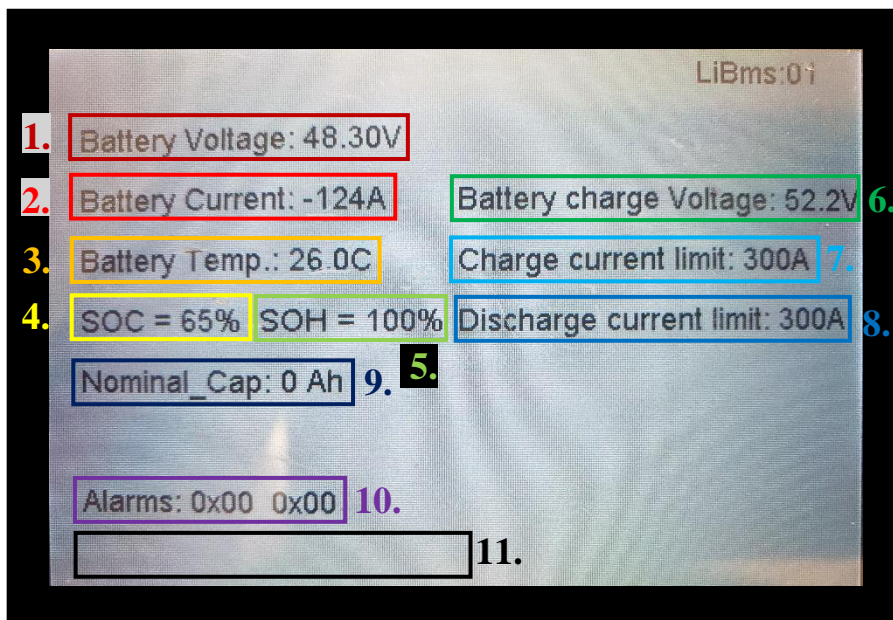

1. **Battery Voltage**: Real-time voltage measured at the battery terminals.
2. **Battery Current**: Real-time current into (positive) or out of (negative) the battery.
3. **Battery Temp**: Real-time temperature measured at the BMS.
4. **SOC**: State of charge remaining in the battery according to the BMS.
5. **SOH**: State of health of the battery according to the BMS.
6. **Battery Charge Voltage**: Maximum voltage the inverter should charge the battery to.
7. **Charge Current Limit**: Maximum allowable current into the battery.
8. **Discharge Current Limit**: Maximum allowable current out of the battery.
9. **Nominal_Cap**: Amp-hour design capacity of the battery (not used on all batteries).
10. **Alarms**: Displays any alarm codes coming from the battery (manufacturer specific).
11. **Force Charge Request**: Command sent by the BMS telling the inverter to charge the battery from any available power source regardless of inverter settings. Not shown on the above image but would be located below the “Alarms” field.

Modbus/RS-485 Battery Screen

The image below depicts the screen shown under “Settings > LI Batt Info” when communications are enabled for Modbus/RS-485 batteries (All other “BMS Lithium Batt” modes).

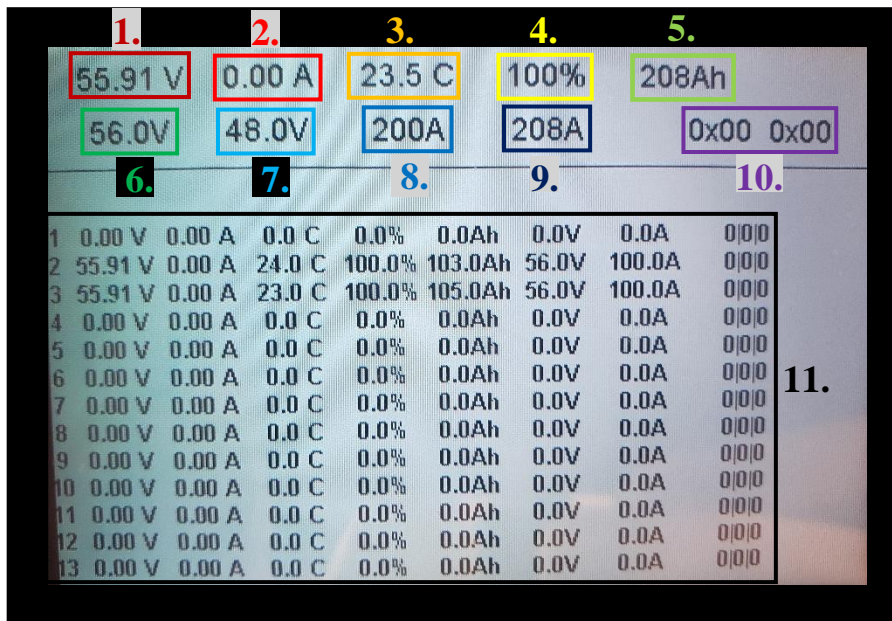

- Battery Voltage:** Real-time voltage measured at the battery terminals.
- Battery Current:** Real-time current into (positive) or out of (negative) the battery.
- Battery Temp:** Real-time temperature measured at the BMS.
- SOC** State of charge remaining in the battery according to the BMS.
- Total Capacity:** Total Amp-Hour capacity connected to the inverter. Not present for all batteries.
- Battery Charge Voltage** Maximum voltage the inverter should charge the battery to.
- Battery Empty Voltage:** Minimum voltage the inverter should discharge the battery to.
- Charge Current Limit:** Maximum allowable current into the battery.
- Discharge Current Limit:** Maximum allowable current out of the battery.
- Alarms:** Displays any alarm codes coming from the battery (manufacturer specific).
- Battery Data Chart:** This table displays individual information from each connected battery up to a maximum of 12 batteries. Not all manufacturers utilize this feature.



- NOTE** that line one (1) is never populated for any manufacturer. The first battery is always displayed on line two (2).

Discover

You will need the Discover Lynk device to adapt the battery's AEBus to CAN Bus for use with the Sol-Ark. The Lynk will need the proper adapter for the Sol-Ark's pin configuration (Part number 950-0016-SLRK).

- Communications with this battery will require a custom cable (outdoor-rated units only).

Communications Installation and Setup Instructions

1. Insert the included RJ45 splitters into the AEBus port of each Discover Battery.
2. Connect and link each battery to the next in a chain using RJ45.
3. Connect either end of the chain of the batteries to the AEBus RJ45 port on the Lynk.
4. Connect the 12V power supply to one of the batteries and plug it into the other end of the chain using an RJ45 cable.
5. Connect the Edge Card's RJ45 port to the CAN Bus port of the Sol-Ark.
 - a. For outdoor-rated units only, create a custom RJ45 cable that connects pins four (4) (solid blue) and five (5) (white-blue) through to the same pins on the inverter and connects pin two (2) (solid orange) on the LYNK side to pin six (6) on the inverter.
 - b. You may use an off-the-shelf ethernet cable for indoor-rated units – no custom cable is needed.
6. Program the inverter with the appropriate charge/discharge settings for this battery.
7. Enable "BMS Lithium Batt" and set its value to "00."
8. (Optional) Turn on "BMS_Err_Stop" if you wish the system could fault on battery communications loss.

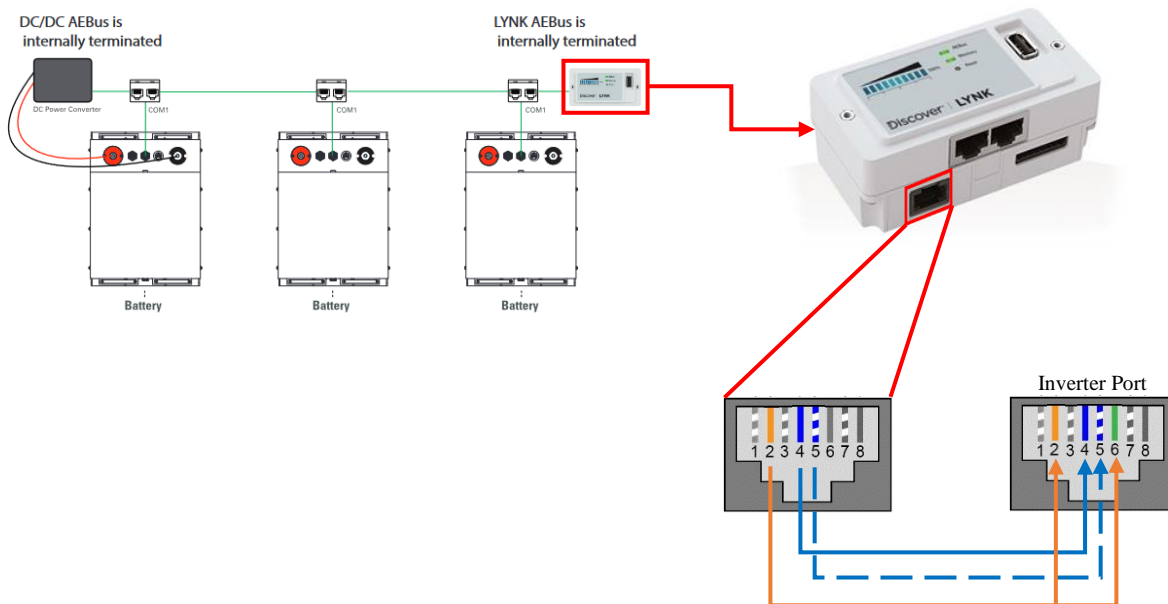

Dyness

Dyness Batteries do not require additional hardware to establish communications.

- Communications with this battery will require a custom cable (Outdoor units only)

Communications Installation and Setup Instructions

1. Ensure correct battery interconnection and connect to the inverter as specified in Dyness' user manual.
2. For outdoor-rated systems only, create a custom RJ45 cable that connects pin two (2) on the battery to pin six (6) on the inverter.
3. Connect one of the batteries to the inverter via the CAN Bus port.
4. Set the switch in position three (3) on the DIP selection switches to the "ON" position for the battery connected to the inverter.
5. Program the inverter with the appropriate charge/discharge settings for this battery.
6. Enable "BMS Lithium Batt" and set its value to "00."
7. (Optional) Turn on "BMS_Err_Stop" if you wish the system could fault on battery communications loss.

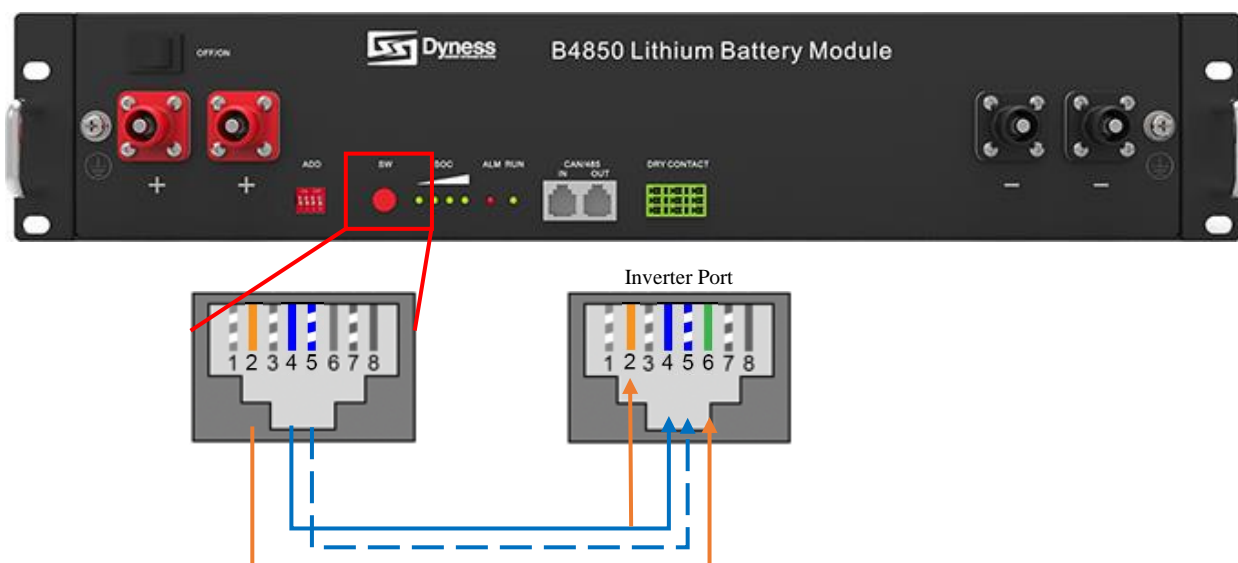

Blue Ion/eGauge

The Sol-Ark will need an eGauge monitoring device, an eGauge USB-485 converter, and a wired internet connection to establish communications with the Blue Ion battery.

- You will need a custom RJ45 cable for this setup.

Communications Installation and Setup Instructions

1. Connect the Blue Ion to your wired internet connection using the RJ45 port on the back of the unit.
2. Connect the eGauge to a power source.
3. Connect the eGauge to your wired internet connection using the RJ45 port on the unit.
4. Follow instructions from eGauge to set up the device with your Blue Ion battery.
5. Connect the USB-485 to the eGauge.
6. Set up the USB-485 using eGauge's online instructions.
7. Enable Modbus RTU on the eGauge.
8. Connect "D+" on the USB-485 to either pin two (2) or pin seven (7).
9. Connect "D-" to either pin one (1) or pin eight (8).
10. GND to either pin three (3) (indoor units only) or pin six (6) (indoor and outdoor units).



NOTE: eGauge needs to configure your device specifically for use with the Sol-Ark. Please verify this by getting in touch with eGauge support.

11. Plug the RJ45 cable into the "RS-485" (indoor models) or "Battery CAN Bus" (outdoor models) port on the inverter.
12. Program the inverter with the appropriate charge/discharge settings for this battery.
13. Enable "BMS Lithium Batt" and set its value to "03."
14. (Optional) Turn on "BMS_Err_Stop" if you wish for the system to fault on loss of battery communications

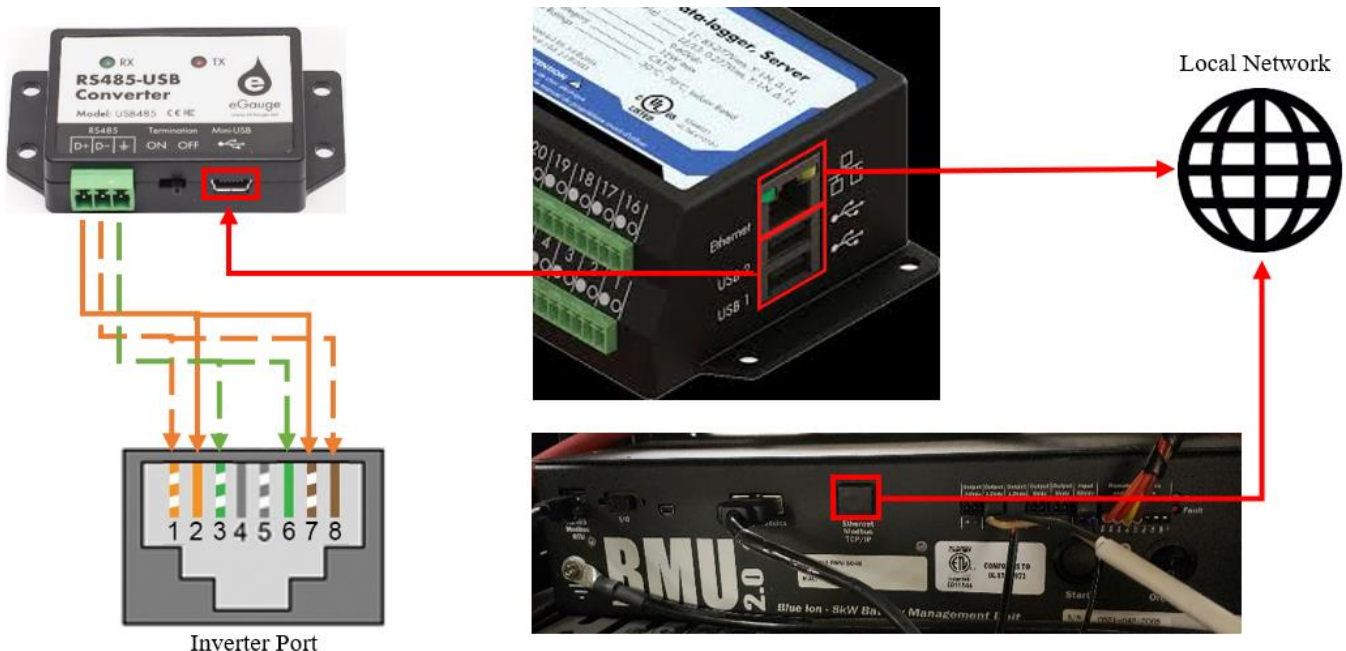

Blue Ion/Namaka

The Sol-Ark will need a Namaka monitoring device and a wired internet connection to establish communications with the Blue Ion battery.

- You will not need to make a custom cable for this setup.

Communications Installation and Setup Instructions

1. Connect all Blue Ion cabinets together using their “RS-485 Modbus RTU” ports and standard RJ45 ethernet cable.
2. Connect the daisy-chained cabinets to the Namaka’s “BMU” port using standard RJ45 ethernet cable.
3. Connect the ethernet port on the Namaka to an active, wired internet connection using standard RJ45 ethernet cable.
 - a. Some Namaka units may be configured for Wireless or no internet connection. Contact Blue Ion for further information.
4. Connect the 12V power connection from the Namaka to the nearest Blue Ion BMU.
5. Connect the “BMS” port on the Namaka to the inverter’s “Battery CAN Bus” port (outdoor units only) or to the “CAN” port (indoor units only).
6. Program the inverter with the appropriate charge/discharge settings for this battery.
7. Power on the Namaka by flipping the DC breaker in the unit’s enclosure.
8. Enable “BMS Lithium Batt” and set its value to “00”.
9. (Optional) Turn on “BMS_Err_Stop” if you wish for the system to fault on loss of battery communications.

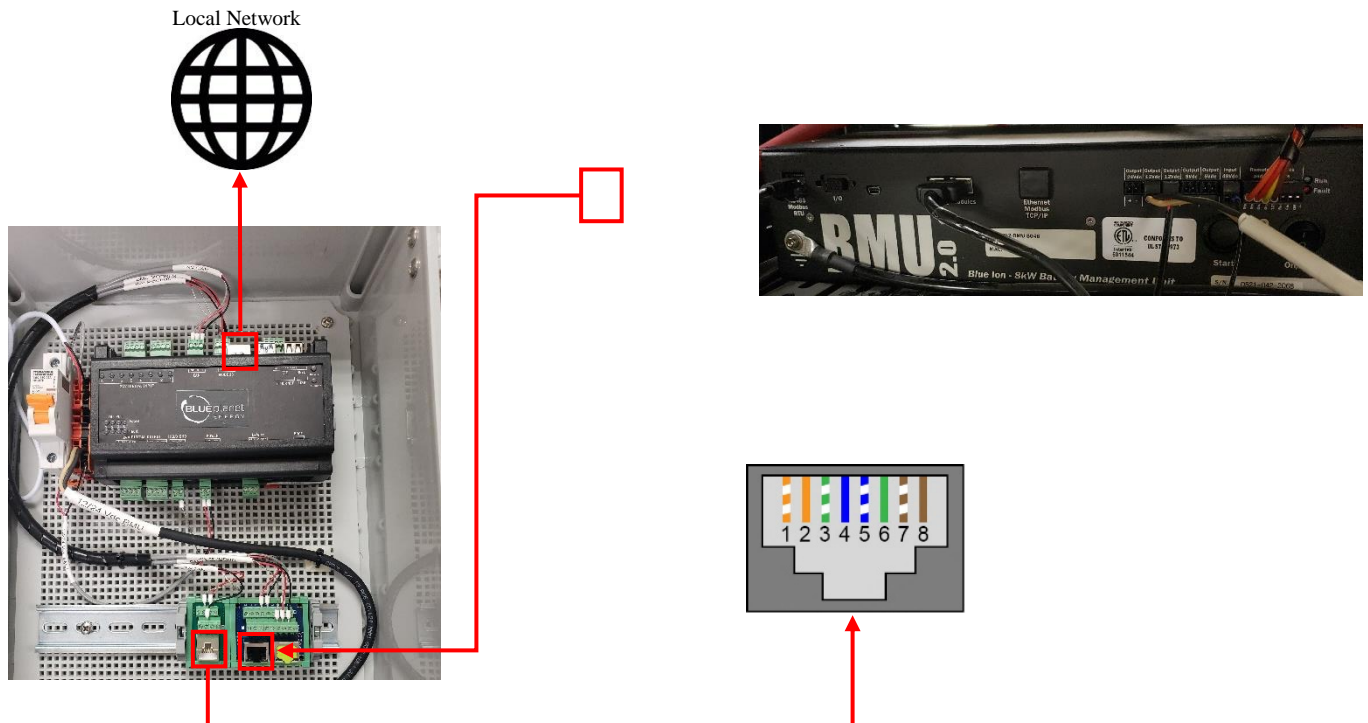

Fortress eFlex 5.4

No additional hardware is required to establish communication with the eFlex 5.4.

- You will need to make a custom cable for this setup.

Communications Installation and Setup Instructions

- Connect all batteries using the included RJ45 cables.
- Use the included 120 Ohm termination resistor on either end of the resulting chain.
- Create a custom RJ45 cable where only pins six (6) (solid green), seven (7) (white-brown), and eight (8) (solid brown) remain connected in their original positions, as shown in the picture below.
 - Using an ethernet cable that is known to work is more accessible and less prone to error. Cut open the cable, and cut the unnecessary wires.**
 - NOTE:** If you are crimping new connectors to create a custom cable, be careful not to over-tighten the crimping tool, as this can recess the connectors and lead to poor or intermittent connection.
- Plug one end of the cable into the CAN/RS485 port on the battery and the other into either the “RS-485” (indoor models) or “Battery CAN Bus” (outdoor models) port on the inverter.
- Program the inverter with the appropriate charge/discharge settings for this battery.
- Enable “BMS Lithium Batt” and set its value to “04.”
- (Optional) Turn on “BMS_Err_Stop” if you wish for the system to fault on loss of battery communications



Fortress eVault & eVault MAX 18.5

No additional hardware is required to establish communication with the Fortress eVault 18.5 battery.

- You will need to make a custom cable for this setup.



NOTE: The original Fortress eVault can only communicate with the Sol-Ark AFTER a firmware update to the eVault. New eVault units (including the eVault MAX) ship with this update; however, older units may need the latest firmware update. To find out if your eVault needs the update and how to perform this update, please get in touch with Fortress Power for details.

Communications Installation and Setup Instructions

1. If using multiple batteries, designate one as master and the others as slaves per Fortress’ setup instructions. If using a single battery, skip to Step 3.
2. Connect the multiple batteries using an ethernet cable (RJ45 cable) as directed in Fortress’ setup instructions.
3. Create a custom cable connecting pins three (3) and five (5) ONLY (white-green and white-blue) to the battery.
4. Pin 3 (white-green) can be connected either to pin two (2) or pin (7) on the inverter.
5. Pin 5 (white-blue) can be connected to either pin one (1) or pin eight (8) on the inverter.
 - a. Since the eVault has no ground pin for communications, we recommend unchecking the “BMS_err_stop” (under battery setup > discharge tab) so that noise on the communications cable does not cause the inverter to throw a fault. This step is not necessary for the eVault MAX as it has a ground connection.
6. Connect this cable between the Fortress eVault’s RS485 port and the “Battery CANBus” port (Outdoor units) or the “RS-485” port (Indoor units).
7. Program the inverter with the appropriate charge/discharge settings for this battery.
8. Enable “BMS Lithium Batt” and set its value to “04.”
9. (Optional) Turn on “BMS_Err_Stop” if you wish for the system to fault on the loss of battery communications

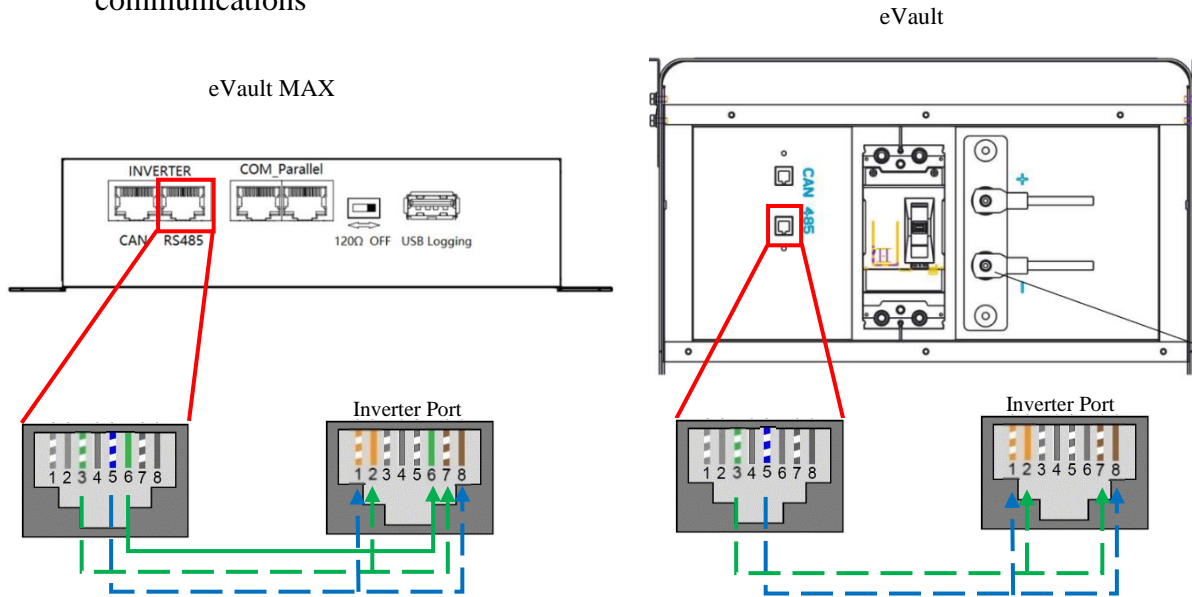

StorzPower

No additional hardware is required to establish communication with StorzPower Resi+ 48V units.

- You will need to make a custom cable for this setup.

Communications Installation and Setup Instructions

1. Use the DIP switches on the batteries such that the battery to be connected to the inverter is set as slave 1, and each unit behind it increases the slave ID it has.
 - a. Each DIP switch (1-4) represents a bit in the slave ID value. i.e. [1: ON 2: OFF 3: ON 4:ON] = 1101 (binary) = 13 (decimal).
2. Connect all batteries with the RJ45 cable such that they are all in parallel.
3. Create a custom cable that connects pins 1, 2, and 3 only (white-orange, solid orange, and white-green) to the battery.
4. Pin 1 (white-orange) can be connected to pin one (1) or pin eight (8) on the inverter and pin 2 (solid orange) can be connected to pin two (2) or pin seven (7) on the inverter.
5. Connect this cable between the battery set as slave one (1) and the inverter's "Battery CANBus" (Outdoor models) or "RS-485" (Indoor models) port.
6. Program the inverter with the appropriate charge/discharge settings for this battery.
7. Enable "BMS Lithium Batt" and set its value to "01."
8. (Optional) Turn on "BMS_Err_Stop" if you wish for the system to fault on loss of battery communications (This may happen more frequently since the Storz Power batteries do not feature ground connections).

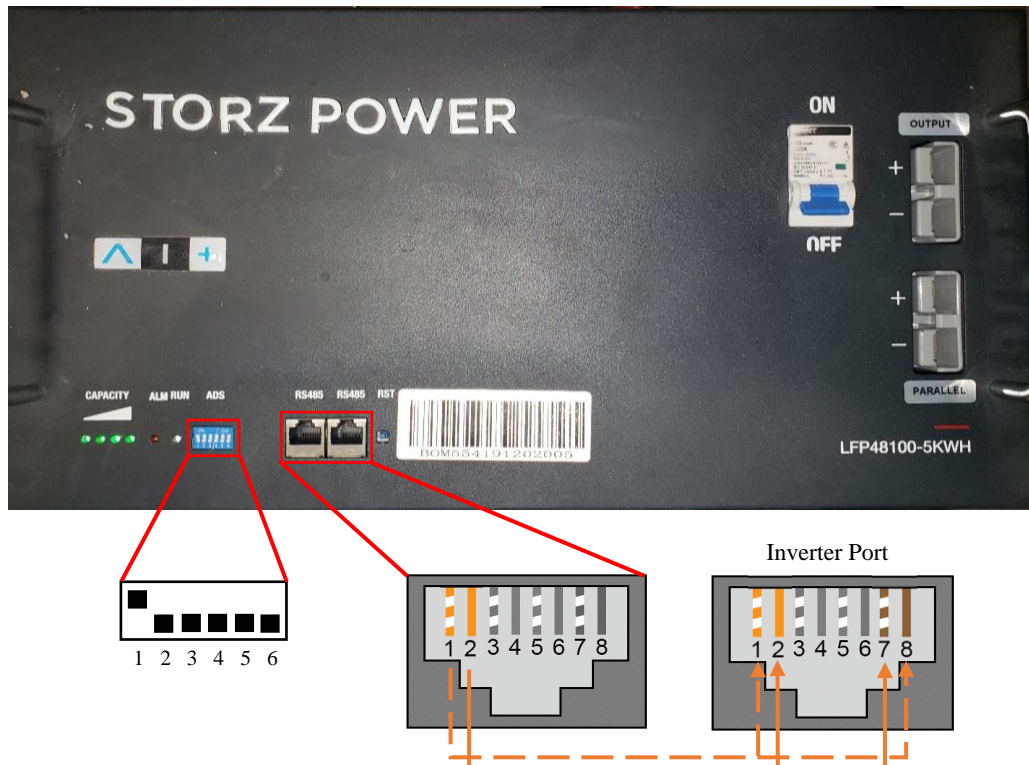

SimpliPhi AmpliPhi

No additional hardware is required to establish communication with SimpliPhi AmpliPhi units.

- You will not need to make a custom cable for this setup.

Communications Installation and Setup Instructions

1. Connect all batteries using the included RJ45 cables, using the two ports nearest each other to bridge the batteries together (GREEN in the picture below).
2. Use the included 120 Ohm terminators on both ends of the resulting chain.
3. Use either the battery from the beginning or the end of the chain. Connect an RJ45 cable from the separate RJ45 port (RED in the picture below) to the “CAN” or “Battery CAN Bus” port on the inverter.
4. Program the inverter with the appropriate charge/discharge settings for this battery.
5. Enable “BMS Lithium Batt” and set its value to “00.”
6. (Optional) Turn on “BMS_Err_Stop” if you wish the system could fault on battery communications loss.

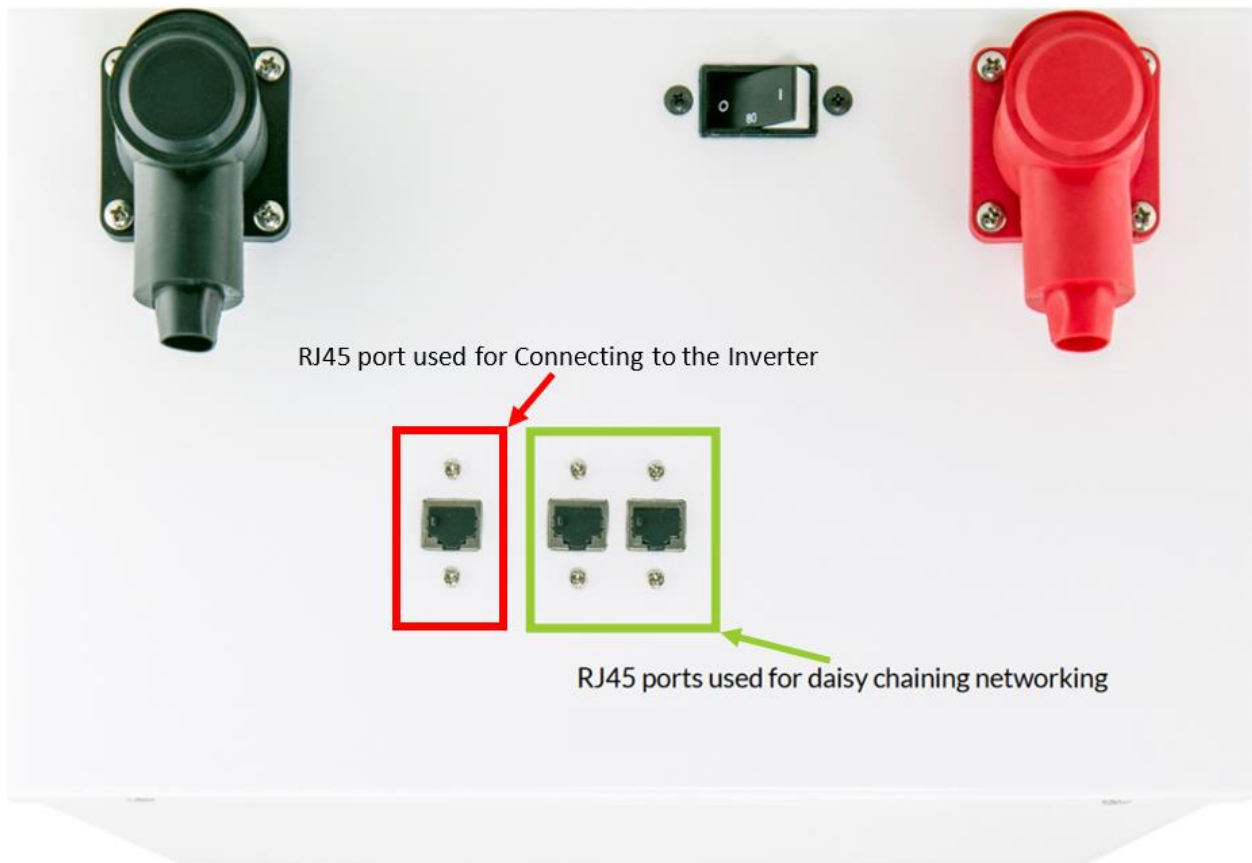

NuEnergy Lithium

No additional hardware is needed to establish communications with NuEnergy Lithium batteries.

- A custom cable is required to establish communications with the NuEnergy Lithium battery.

Communications Installation and Setup Instructions

1. Create a custom cable that connects pins 2, 3, and 4 ONLY (solid orange, white-green, and solid blue) to the battery.
2. Pin two (2) (solid orange) should connect to pin six (6) on the inverter.
3. Pin three (3) (white-green) should connect to pin five (5) on the inverter. Pin four (4) (solid blue) should connect to pin four (4) on the inverter.
 - a. On indoor units, leave pin two (2) (solid orange) connected to pin two (2) on the inverter instead of pin six (6).
4. Connect the cable to the “CAN” port on the NuEnergy cabinet and the “Battery CAN Bus” port (or the “CAN” port for indoor-only units) on the Sol-Ark.
 - a. The cable is NOT reversible; therefore, keep track of which end of the custom cable connects to the battery and the Sol-Ark.
5. Turn on the battery. Start by flipping the “ON” switch for every battery. Then, press the circular button at the top of the inside of the unit.
6. Program the inverter with the appropriate charge/discharge settings for this battery.
7. Enable “BMS Lithium Batt” and set its value to “00.”
8. (Optional) Turn on “BMS_Err_Stop” if you wish the system could fault on battery communications loss.

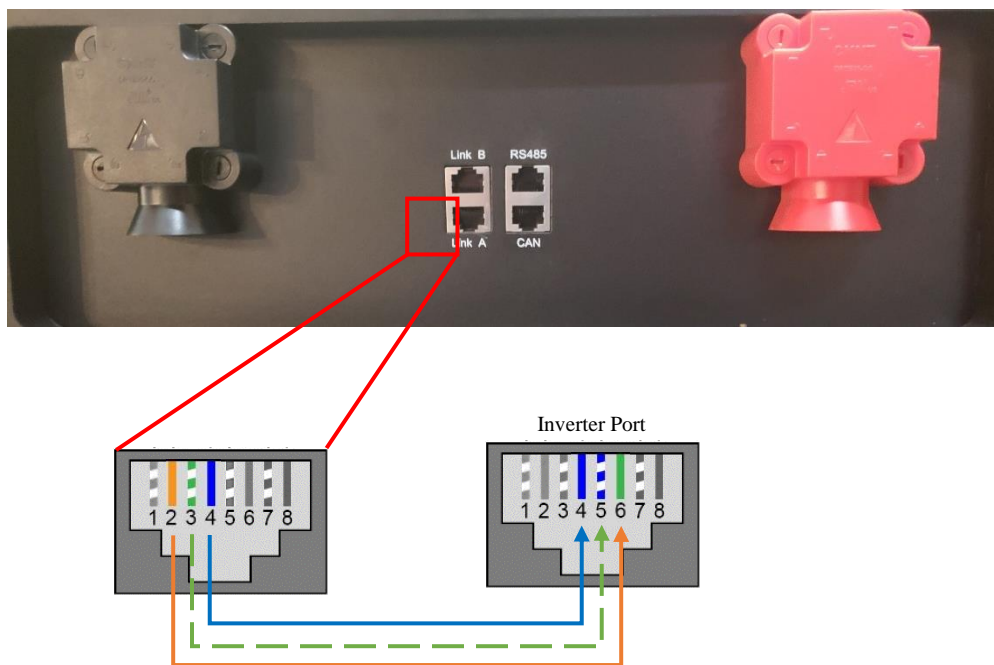

NuEnergy Lithium- Power Base M50

No additional hardware is needed to establish communications with NuEnergy Lithium batteries.

- A custom cable is required to establish communications with the NuEnergy Lithium battery.

Communications Installation and Setup Instructions

1. Create a custom cable that connects pins 6, 7, and 8 ONLY (solid green, white-brown, and solid brown) to the battery.
2. Pin six (6) (solid green) should connect to pin six (6) on the inverter.
3. Pin seven (7) (white-brown) should connect to pin five (5) on the inverter. Pin eight (8) (solid brown) should connect to pin four (4) on the inverter.
 - a. On indoor units, connect pin six (6) (solid green) to pin two (2) on the inverter instead of pin six (6).
4. Connect the cable to the “CAN” port on the NuEnergy and the “Battery CAN Bus” port (or the “CAN” port for indoor-only units) on the Sol-Ark.
 - a. The cable is NOT reversible; therefore, keep track of which end of the custom cable connects to the battery and the Sol-Ark.
5. Turn on the battery by pressing the power switch and hold for 3 seconds then a display will light up and the system will start to switch on all the battery systems.
6. Program the inverter with the appropriate charge/discharge settings for this battery.
7. Enable “BMS Lithium Batt” and set its value to “00.”
8. (Optional) Turn on “BMS_Err_Stop” if you wish the system could fault on battery communications loss.

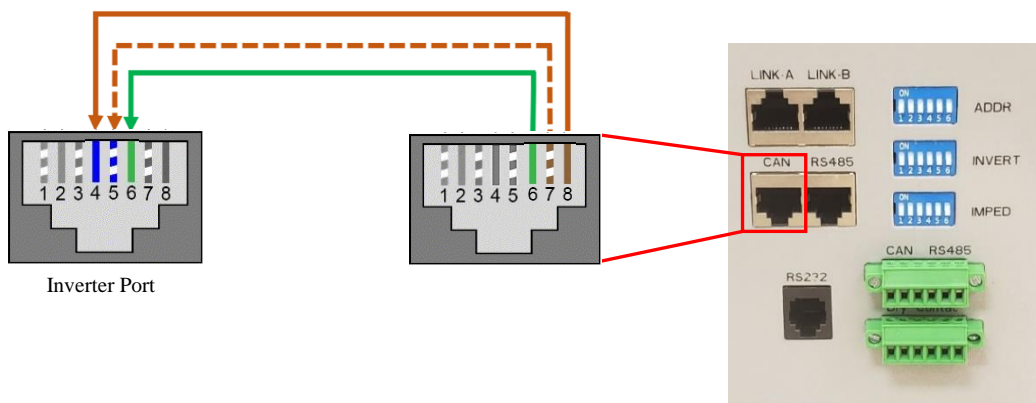

PowerSync 51.2V Lithium

No additional hardware is required to establish communication with PowerSync 51.2V Lithium batteries.

- You will not need to make a custom cable for this setup.

Communications Installation and Setup Instructions

1. Set the DIP switches on the battery per the manual and your battery configuration.
2. Connect all batteries with the included short RJ45 cables, connecting each battery via their RS485 ports.
3. Connect the master battery's "CAN" port to the inverter's "Battery CAN Bus" port (or to the inverter's "CAN" port for indoor-only units) using a standard RJ45 ethernet cable.
4. Turn on the batteries using the breaker labeled "Master Switch."
5. Program the inverter with the appropriate charge/discharge settings for this battery.
6. Enable "BMS Lithium Batt" and set its value to "00."
7. (Optional) Turn on "BMS_Err_Stop" if you wish the system could fault on battery communications loss.

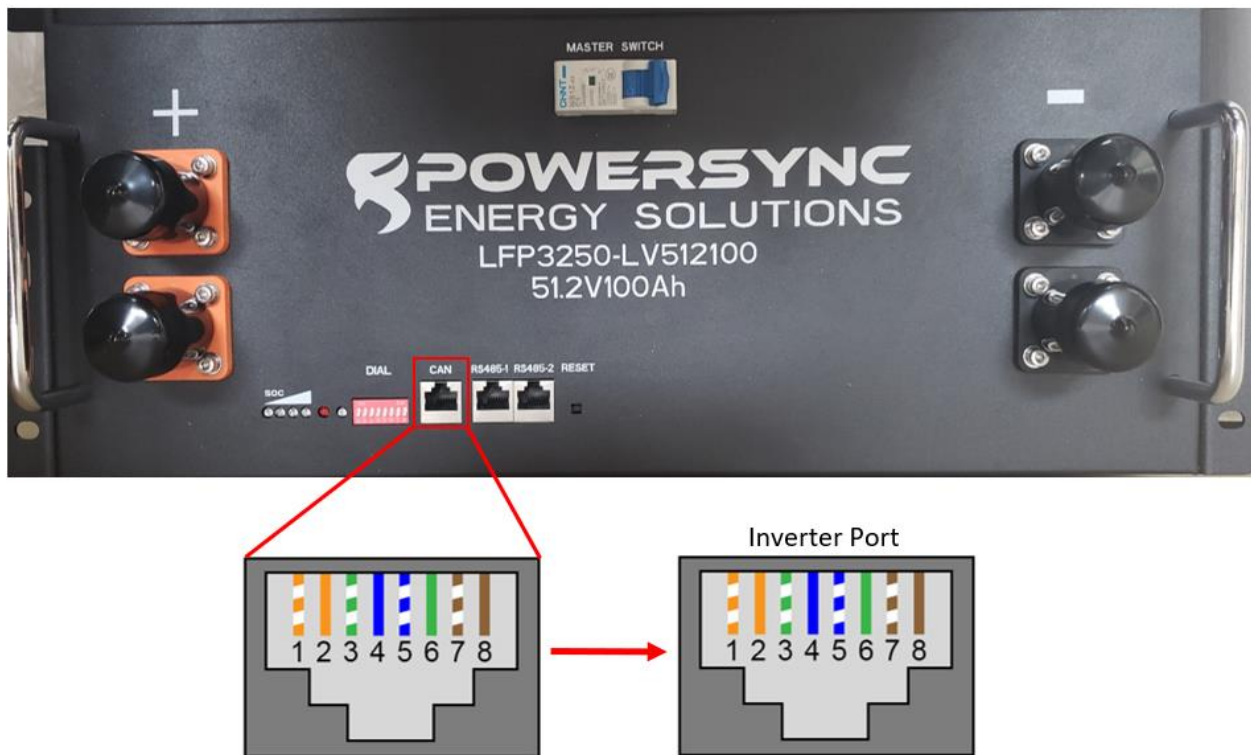

KiloVault HAB

No additional hardware is required to establish communications with KiloVault HAB batteries.

- You will not need to make a custom cable for setup with a HAB V4, but a custom cable is necessary for HAB V3 or older models.

Communications Installation and Setup Instructions

1. Ensure that the batteries are running the latest firmware from KiloVault and that the Sol-Ark communication profile is selected.
 - a. If unsure, contact KiloVault to verify.
2. Set the DIP switches following the KiloVault manual.
 - a. If only using a single battery, all DIP switches should be “OFF.”
 - b. If using more than one battery, the battery connected to the inverter should have only DIP switch one (1) turned “ON.” Set DIP switches of all subsequent batteries according to what number they are in the chain (the DIP switches represent the binary number of the battery).
 - c. A theoretical maximum of 15 batteries can be communicating in parallel at the same time. More than one unit still untested but should work.
3. (HAB V3 or older only) Create a custom cable such that the “Inverter RS485B” wire connects to pin 1 (white- orange) and “Inverter RS485A” connects to pin 2 (solid orange).
4. Connect the custom 6-pin connector to the KiloVault’s custom port and connect the custom RJ45 cable to the “Battery CAN Bus” (outdoor units) or “RS-485” (indoor units) port on the inverter.
5. Program the inverter with the appropriate charge/discharge settings for this battery.
6. Enable “BMS Lithium Batt” and set its value to “05”.
7. (Optional) Turn on “BMS_Err_Stop” if you wish for the system to fault on loss of battery communications (This may happen more frequently since the KiloVault HAB batteries do not feature ground connections).

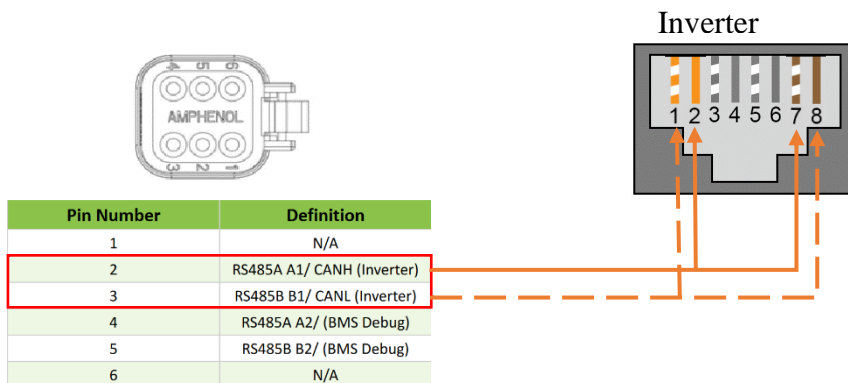

Sacred Sun LFP

No additional hardware is required to establish communications with Sacred Sun LFP batteries.

- You will need to make a custom cable for this setup.

Communications Installation and Setup Instructions

- Use the DIP switches on the batteries such that the battery to be connected to the inverter is set as slave 1, and each unit behind it increases the slave ID it has.
 - Each DIP switch (1-4) represents a bit in the slave ID value. i.e. [1: ON 2: OFF 3: ON 4:ON] = 1101 (binary) = 13 (decimal).
- Connect all batteries with the RJ45 cable such that they are all in parallel.
- Create a custom cable that connects pins 1, 2, and 3 only (white-orange, solid orange, and white-green) to the battery.
- Pin 1 (white-orange) can be connected to pin one (1) or pin eight (8) on the inverter, Pin 2 (solid orange) can be connected to pin two (2) or pin seven (7) on the inverter.
- Connect this cable between the battery set as slave one (1) and the inverter's "Battery CANBus" (Outdoor models) or "RS-485" (Indoor models) port.
- Program the inverter with the appropriate charge/discharge settings for this battery.
- Enable "BMS Lithium Batt" and set its value to "01."
- (Optional) Turn on "BMS_Err_Stop" if you wish for the system to fault on loss of battery communications (This may happen more frequently since the Sacred Sun batteries do not feature ground connections).

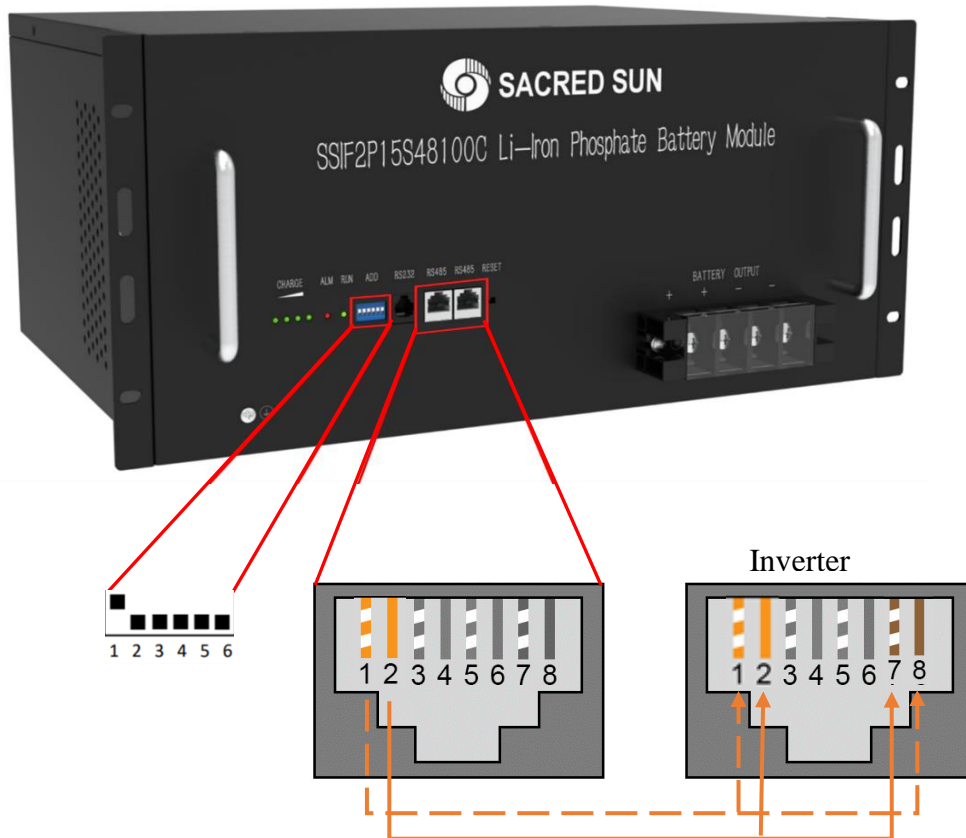

HomeGrid Stack'd

No Additional hardware is required to establish communications with HomeGrid Stack'd batteries.

- You will need to make a custom cable for this setup.

Communications Installation and Setup Instructions

1. Set the DIP switches on each battery according to the battery manual.
2. Connect all top modules (if in parallel) together with RJ45 cable between their “Link A” and “Link B” ports. It does not matter which port is connected to which.
3. Create a custom cable that connects pins 6, 7, and 8 ONLY (solid-orange, white-green, and solid-blue) to the battery.
4. Pin six (6) (solid-green) need to connect to pin six (6) on the inverter.
5. Pin seven (7) (white-brown) need to connect to pin four (4) on the inverter.
6. Pin eight (8) (solid-brown) need to connect to pin five (5) on the inverter.
 - a. On indoor units, pin six (6) (solid-green) need to connect to pin two (2) on the inverter.
7. Connect the cable between the master battery’s top module and the inverter’s “Battery CANBus” (Outdoor models) or “CAN” (Indoor models) port.
8. Power on the battery units by turning on each module, followed by that stack’s top module.
9. Program the inverter with the appropriate charge/discharge settings for this battery.
10. Enable “BMS Lithium Batt” and set this value to “00”.
11. (Optional) Turn on “BMS_Err_Stop” if you wish the system could fault on battery communications loss.
12. If communication is still not established, contact HomeGrid to ensure that the unit is on the latest firmware and configured for communication with Sol-Ark inverters.

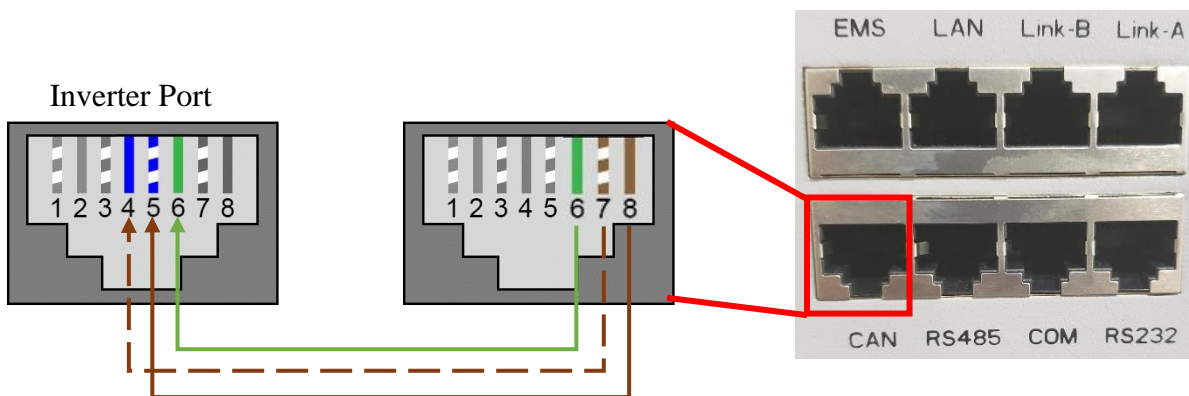

Deka-Duration-DD5300

No additional hardware is needed to establish communications with Deka-DD5300 batteries.



- Please ensure that you are not wiring to the High Voltage connection terminals of Deka-DD5300 battery.

- Please refer to the Installation & Operation (I&O) manual of the battery manufacturer and verify the proper communications configuration of CAN bus connections and dip switch settings:
- A custom cable is required to establish communications with Deka-DD5300 batteries.

Communications Installation and Setup Instructions

1. Create a custom cable that connects pins 1, 2, and 3 ONLY (white-orange, solid orange, and white-green) on the battery.
2. Pin three (3) (white-green) should connect to pin six (6) on the inverter.
3. Pin one (1) (white-orange) should connect to pin four (4) on the inverter. Pin two (2) (solid orange) should connect to pin five (5) on the inverter.
 - a. On indoor units, connect pin three (3) (white-green) to pin two (2) on the inverter instead of pin six (6).
4. Connect the cable to the “CAN-A” port on the Deka-DD5300 and the “Battery CAN Bus” port (or the “CAN” port for indoor-only units) on the Sol-Ark.
 - a. The cable is NOT reversible; therefore, keep track of which end of the custom cable connects to the battery and the Sol-Ark.
5. Turn on the mechanical POWER SWITCH to enable the BMS on all battery modules.
6. Press and hold the RUN BUTTON for 2 seconds on the MASTER battery module only and allow other modules to turn themselves on automatically. After a successful startup of the battery modules the LED status indicator should turn solid green.
7. Program the inverter with the appropriate charge/discharge settings for this battery.
8. Enable “BMS Lithium Batt” and set its value to “00.”
9. (Optional) Turn on “BMS_Err_Stop” if you wish for the system to fault on loss of battery communications.

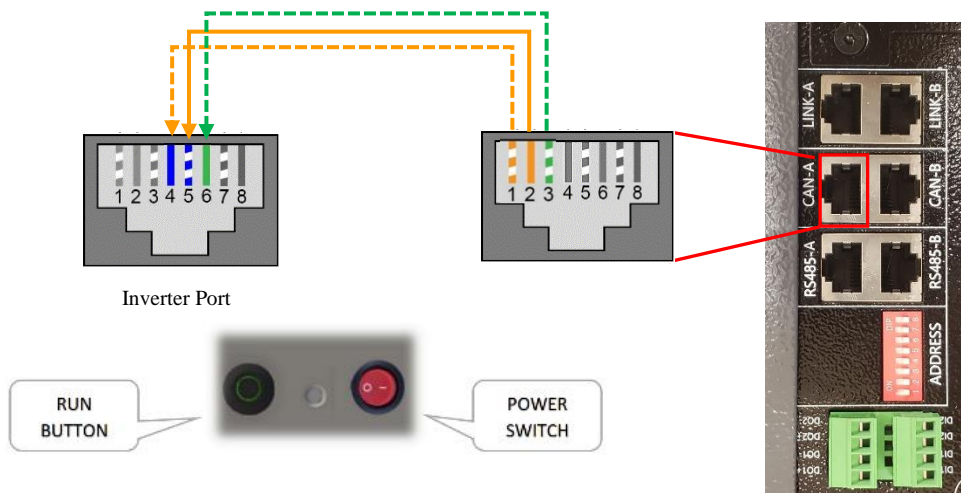

PYLONTECH US3000C

No additional hardware is required to establish communications with Pylontech US3000C batteries. (Consult Pylontech for other compatible battery modules for communication)

- You will need to make a custom cable for this setup.

Communications Installation and Setup Instructions

1. Connect all batteries with the RJ45 cable from Link Port 1 to Link Port 0. The first battery with Link Port 0 empty would be the master battery. (Can use up to 16 batteries with 1 master battery and 15 slave batteries)
2. Set the ADD switch according to the battery manual if more than one string of batteries is in the battery bank.
3. Create a custom cable that connects pins 4, 5, and 6 ONLY (solid-blue, white-blue, and solid-green) to the battery.
4. Pin four (4) (solid-blue) need to connect to pin four (4) on the inverter.
5. Pin five (5) (white-blue) need to connect to pin five (5) on the inverter.
6. Pin six (6) (solid-green) need to connect to pin six (6) on the inverter.
 - a. On indoor units, pin six (6) (solid-green) need to connect to pin two (2) on the inverter.
7. Connect the cable to the “A/CAN” port on the Pylontech master battery and the “Battery CAN Bus” port (or the “CAN” port for indoor-only units) on the Sol-Ark.
 - a. The cable is NOT reversible for indoor units; therefore, keep track of which end of the custom cable connects to the battery and the Sol-Ark.
8. Program the inverter with the appropriate charge/discharge settings according to the specific battery manual.
9. Enable “BMS Lithium Batt” and set its value to “00”.
10. (Optional) Turn on “BMS_Err_Stop” if you wish for the system to fault on loss of battery communications (Pylontech recommend leaving the “BMS_Err_Stop” on in order to better protect their batteries)

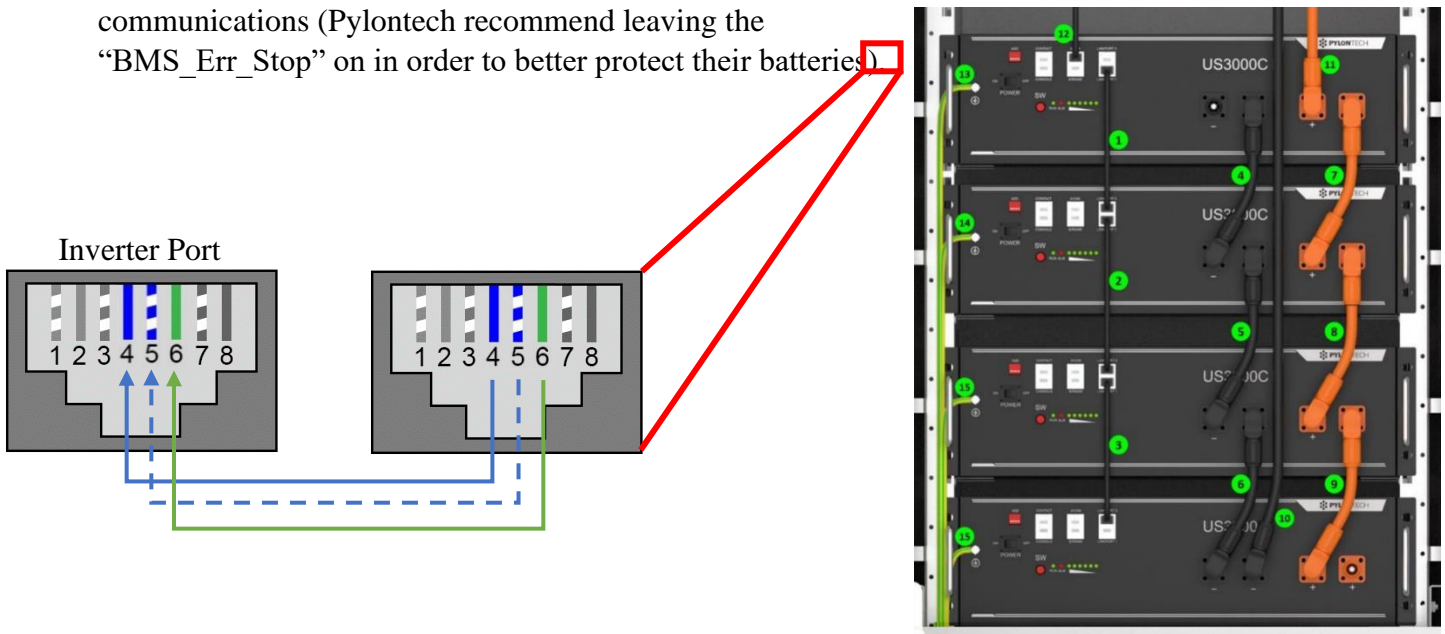

PYTES E-BOX-48100R

No additional hardware is required to establish communications with PYTES E-BOX-48100R batteries. (Consult PYTES for other compatible battery modules for communication)

- You will not need to make a custom cable for this setup.

Communications Installation and Setup Instructions

1. Connect all batteries with the provided RJ45 cable from Link Port 1 to Link Port 0. The first battery with Link Port 0 empty would be the host battery. (Can use up to 16 batteries with 1 master battery and 15 slave batteries)
2. Set the ADD switch according to the battery manual.
3. Connect the cable to the “CAN” port on the PYTES E-BOX host battery and the “Battery CAN Bus” port (or the “CAN” port for indoor-only units) on the Sol-Ark.
4. Program the inverter with the appropriate charge/discharge settings according to the specific battery manual and cable arrangement.
5. Enable “BMS Lithium Batt” and set its value to “00”.
6. (Optional) Turn on “BMS_Err_Stop” if you wish for the system to fault on loss of battery communications (PYTES recommends leaving the “BMS_Err_Stop” on in order to better protect their batteries).

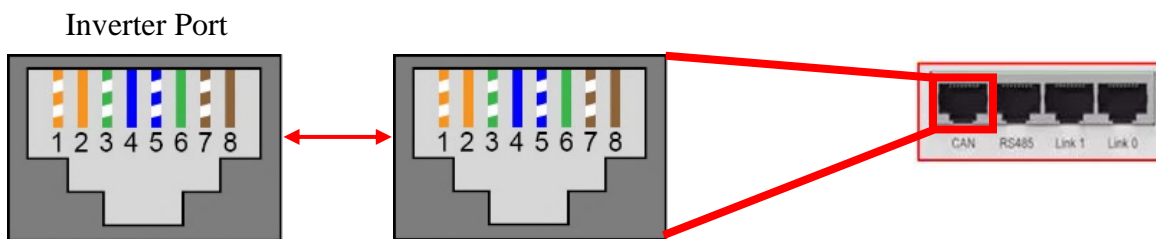

EndurEnergy ESP-5100

No additional hardware is required to establish communications with EndurEnergy ESP-5100 batteries.

- You will not need to make a custom cable for this setup.

Communications Installation and Setup Instructions

1. Connect all EndurEnergy ESP-5100 batteries together with the provided RJ45 cable using “M/S” ports. (Can use up to 8 batteries in 48V low voltage configuration)
2. Set all the dip switches according to the battery manual and double-check all dip switches on all batteries in the battery bank.
3. Connect a standard CAT5/6 cable to the “Inverter” port on the ESP-5100 Master battery, and the “Battery CAN Bus” port (or the “CAN” port for indoor-only units) on the Sol-Ark.
4. Program the inverter with the appropriate charge/discharge settings according to the specific battery manual and cable arrangement.
5. Enable “BMS Lithium Batt” and set its value to “00”.
6. (Optional) Turn on “BMS_Err_Stop” if you wish for the system to fault on loss of battery communications.

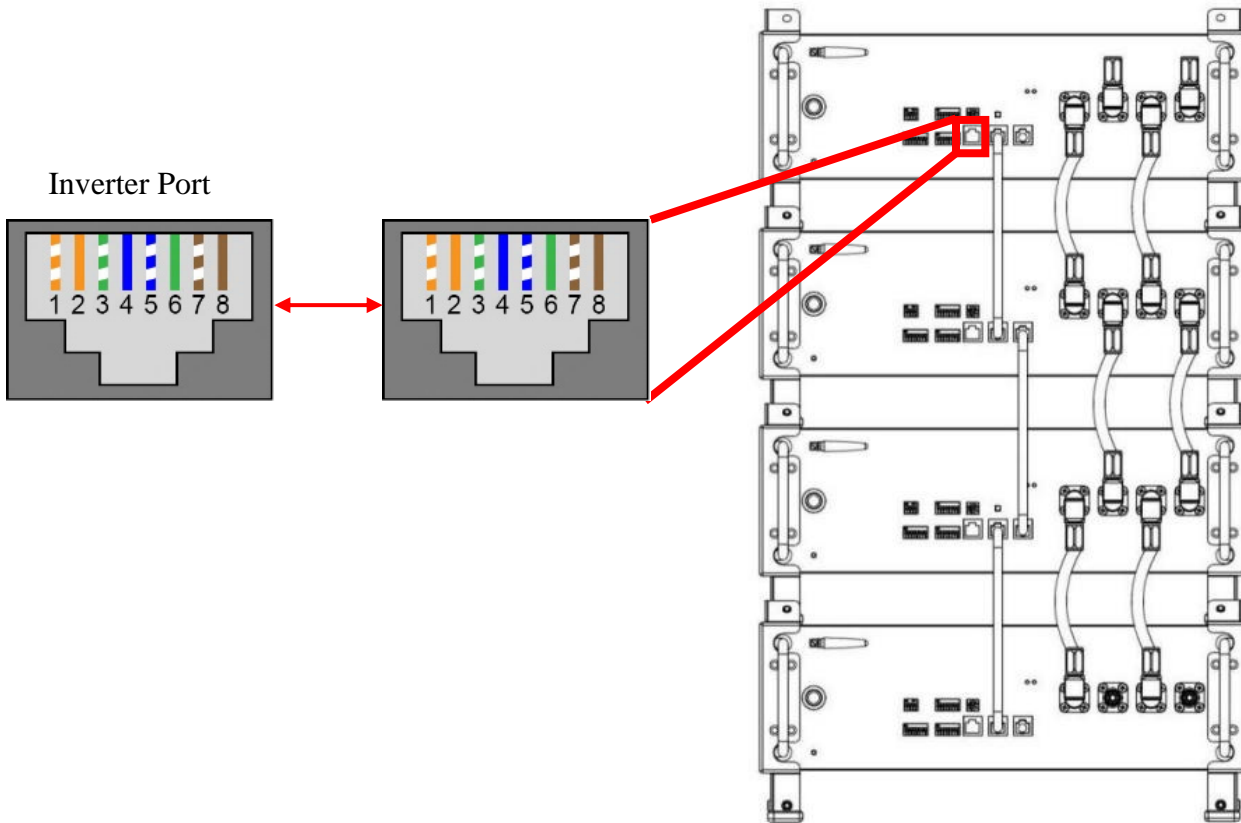

UZ Energy Power Lite (L051100-B)

No additional hardware is required to communicate with UZ Energy Power Lite batteries. (Consult UZ Energy for other compatible battery modules for communication)

- You will need to make a custom cable for this setup.

Communications Installation and Setup Instructions

9. Connect all batteries together with the provided RJ45 cable using the “RS485” ports. (Can use up to 16 batteries with 1 master battery and 15 slave batteries)
10. Set the ADD switch according to the battery manual and double check ADD switch settings before turning on the battery bank.
11. Create a custom cable that connects pins 1, 5, and 6 ONLY (white-orange, white-blue, and solid-green) to the battery.
12. Pin one (1) (white-orange) need to connect to pin four (4) on the inverter.
13. Pin five (5) (white-blue) need to connect to pin five (5) on the inverter.
14. Pin eight (8) (solid-brown) need to connect to pin six (6) on the inverter.
 - a. On indoor units, pin eight (8) (solid-brown) need to connect to pin two (2) on the inverter.
15. Connect the cable to the “CAN/RS485” port on the UZ Energy Power Lite master battery and the “Battery CAN Bus” port (or the “CAN” port for indoor-only units) on the Sol-Ark.
 - a. The cable is NOT reversible; therefore, keep track of which end of the custom cable connects to the battery and the Sol-Ark.
16. Program the inverter with the appropriate capacity and charge/discharge settings according to the specific battery manual and cable arrangement.
17. Enable “BMS Lithium Batt” and set its value to “00”.
18. (Optional) Turn on “BMS_Err_Stop” if you wish the system could fault on battery communications loss.

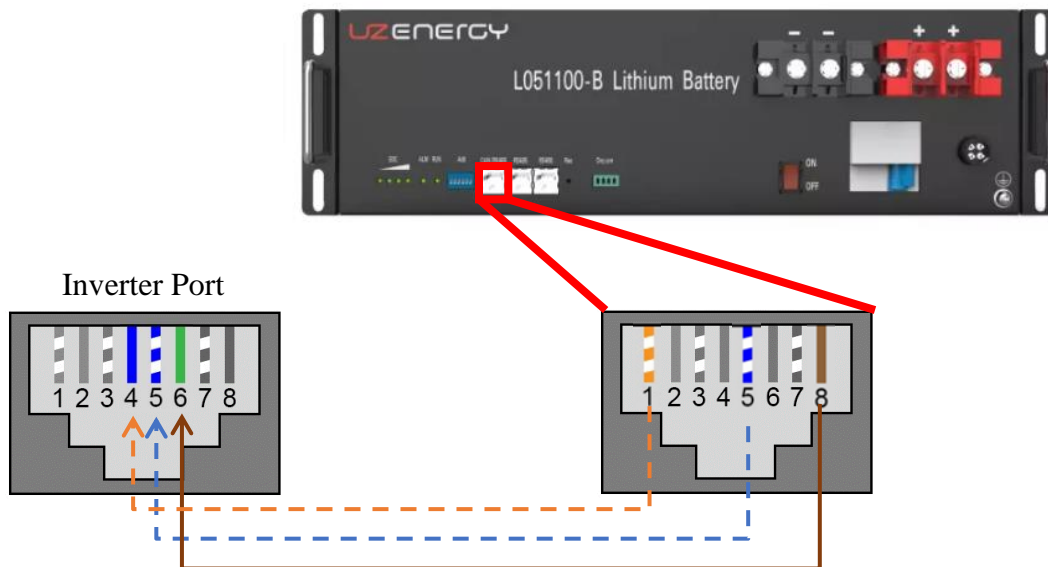

IncCell / Polarium

The Polarium Connect Bridge is required to establish communication with Polarium/IncCell 100/200 Ah battery banks. You will need to make a custom cable for this setup.

Communications Installation and Setup Instructions

Connect all batteries to one another using the included RJ45 cable, using the included terminator on the remaining port of either the first or last battery in the chain.

1. Connect the RJ45 cable attached to the Connect Bridge to the last open port on either the first or last battery in the chain. Insert the included terminator into the leftmost port on the front of the Connect Bridge.
2. Connect the power leads from the Connect Bridge to the battery terminals.
3. Turn on the breaker of each battery in the chain and power on one battery (it does not matter which) by holding the power button on the right side of the unit for about 5 seconds.
4. Using the Polarium Connect app (currently unreleased as of 8/2/2021), find and connect to the device labeled “Connect Bridge” within one minute of the connect bridge powering up.
 - a. Scan the QR code on the front of the Connect Bridge for the app to connect.
 - b. If you are connected, the “IncCell” green led indicator on the front of the unit will stop flashing.
 - c. If you miss the one-minute connect window, you must power down the batteries completely by flipping each breakers and holding the power button down for each one. Power the batteries back on and try again.
5. Under the “About Device” tab, ensure that the unit is running firmware version 0.3.8 or higher.
6. Under the “Configuration” tab, ensure that “Integrated Control” is enabled.
 - a. If it is not enabled, then enable it and reboot the connect bridge using the “Reboot” button under the “About Device” tab.
7. Create a custom cable such that Pin 1 (white orange) on one end is connected to pin 5, Pin 2 (solid orange) on one end is connected to pin 4, and Pin 6 (solid green) on one end is connected to Pin 6.
8. Connect the end with pins 4, 5, and 6 used to the middle port on the Connect Bridge, and plug the other end with pins 1, 2, and 6 used to the “Battery CAN Bus” (for outdoor units) or to the “RS-485” (for indoor units) port on the inverter.
9. Enable “BMS Lithium Batt” and set its value to “03”.

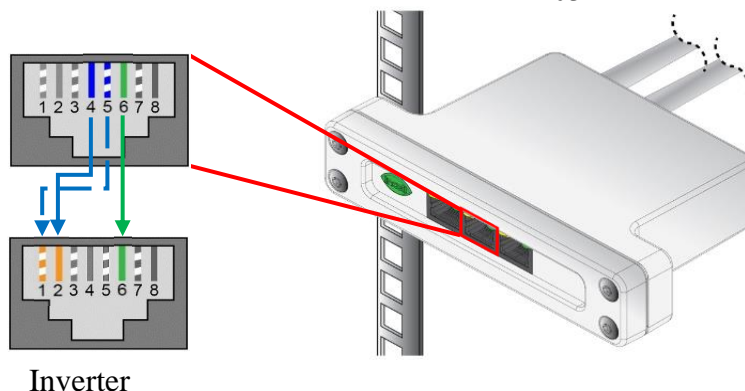

Renogy AURA

No additional hardware is required to establish communications with Renogy AURA batteries.

- You will not need to make a custom cable for this setup.

Communications Installation and Setup Instructions

1. Follow the instructions for installation and wiring in the battery manual.
2. Connect a standard CAT5/6 cable to the “485/CAN” port on the control box of the battery cluster and the “Battery CAN Bus” port (or the “CAN” port for indoor-only units) on the Sol-Ark.
3. Program the inverter with the appropriate charge/discharge settings according to the specific battery manual.
4. Enable “BMS Lithium Batt” and set its value to “00”.
5. (Optional) Turn on “BMS_Err_Stop” if you wish the system could fault on battery communications loss.

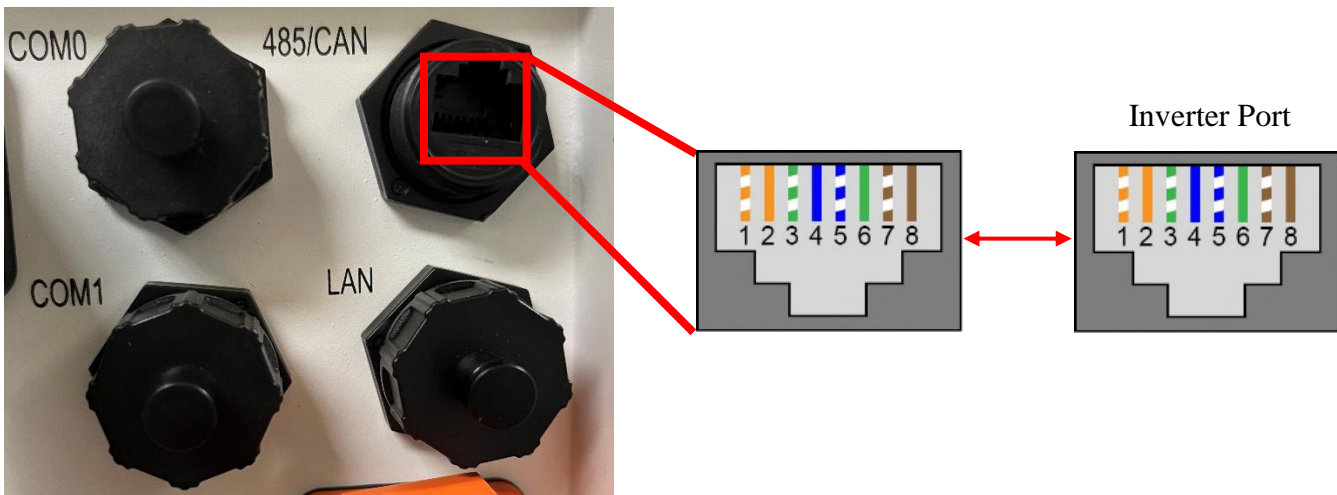

| Revision | Changelog | Author / Editor | Date |
|-----------------|------------------------------------------------------------------------------------------------------------------------------------------------------------------------------------------------------------------------|-----------------------------|-------------|
| 1.0 | Initial creation | William Hopkins | 1/13/21 |
| 1.1 | Updated Storz & eFlex information | William Hopkins | 2/9/21 |
| 1.2 | Updated CAN Pinout for Indoor units | William Hopkins | 2/10/21 |
| 1.3 | | William Hopkins | 2/11/21 |
| 1.4 | Updated Pinouts | William Hopkins | 3/4/21 |
| 1.5 | Added NuEnergy and PowerSync | William Hopkins | 4/29/21 |
| 1.6 | Added Fortress eVault | William Hopkins | 5/11/21 |
| 1.7 | Corrections to StorzPower Pinout | William Hopkins | 7/28/21 |
| 1.8 | Added KiloVault HAB 7.5 | William Hopkins | 8/2/21 |
| 1.9 | Added Sacred Sun LFP | William Hopkins | 10/5/21 |
| 2.0 | Updated document layout and appearance. | Bernie D. | 10/5/21 |
| 2.1 | Corrected Discover LYNK Instructions/ Sacred Sun Pins | William Hopkins/Bernie D. | 10/18/21 |
| 2.2 | Added HomeGrid Stackd & Fixed StorzPower Pinout | William Hopkins | 1/20/22 |
| 2.3 | Added NuEnergy Power Base M50, Blue Ion with Namaka, Fortress eVault max, & Deka Duration- 5300 Updated Sacred Sun pinout Added inverter BMS data screen key. Re-created graphics for battery cable diagrams. | Mahir Sukar/William Hopkins | 2/10/22 |
| 2.4 | Added DEKA Duration DD5300 | Mahir Sukar | 3/14/22 |
| 2.5 | Added Pylontech US3000C | Vincent Wei | 4/21/22 |
| 2.6 | Added PYTES E-BOX-48100R | Vincent Wei | 6/01/22 |
| 2.7 | Added "Sol-Ark 15K" Info | Vincent Wei | 6/29/22 |
| 2.8 | Added EndurEnergy, Incell/Polarium and UZ Energy Document cleanup and corrections | Vincent Wei | 8/05/22 |
| 2.9 | Changed port screen capture to reflect the new PYTES battery appearance, Added Renogy AURA | Daniel Oyedapo Bernie D. | 10/24/22 |